

## Kan de CUR226-ontwerprichtlijn paalmatrassen beter?

Suzanne van Eekelen

Deltares, Delft University of Technology, NGO-I&K

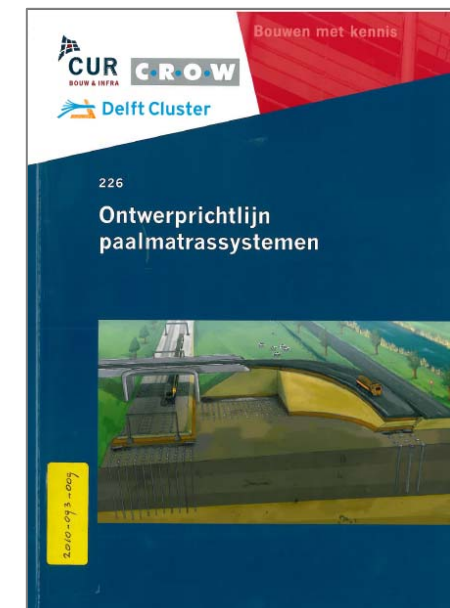

# Wat is een paalmatras?

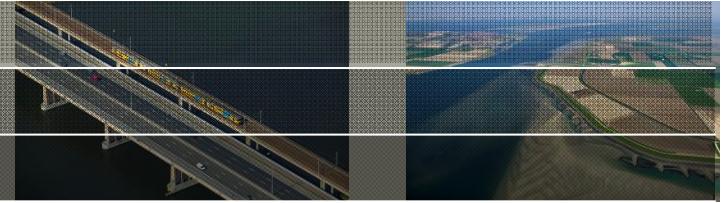

GR = geosynthetic reinforcement

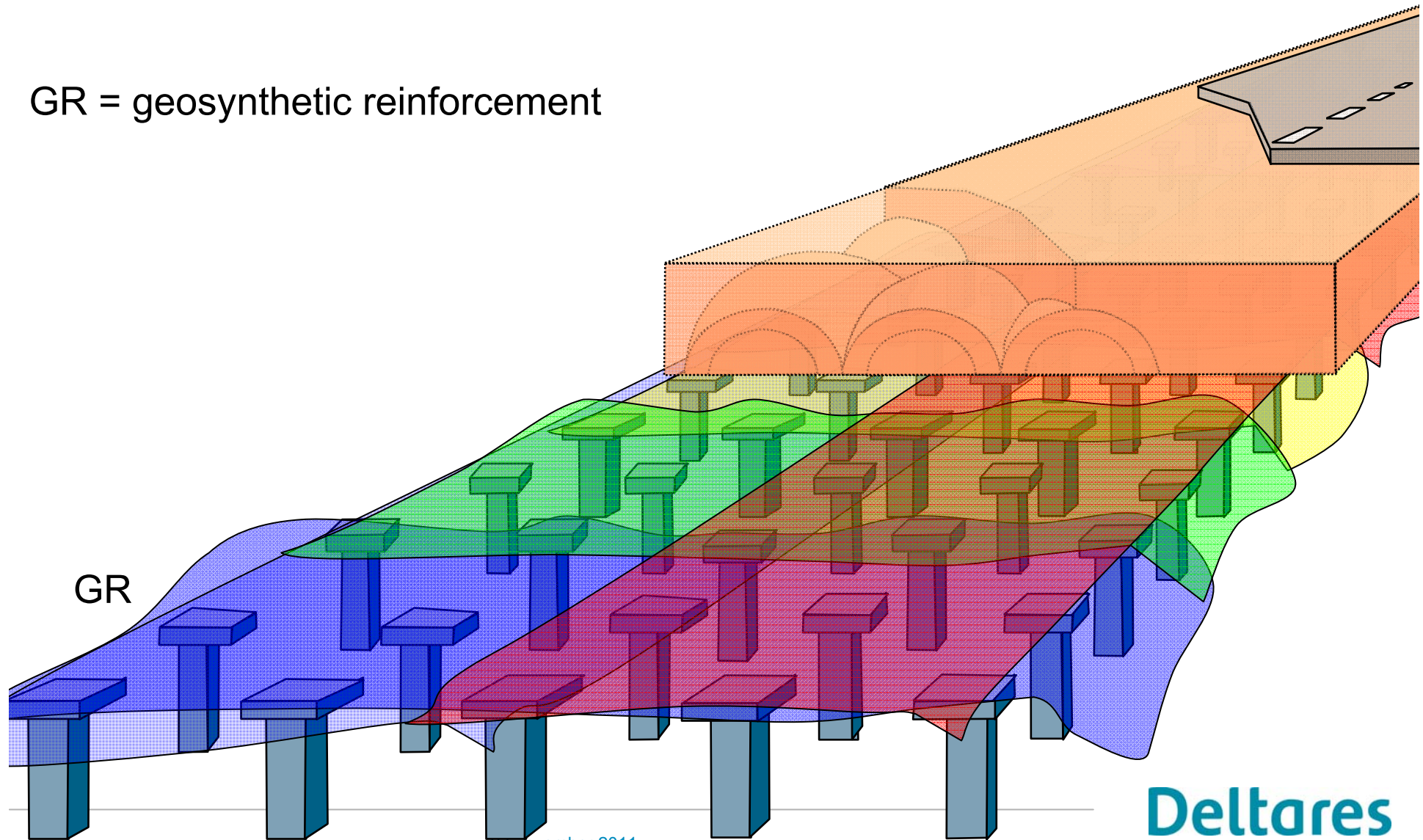

GR

# Ontwerprichtlijnen

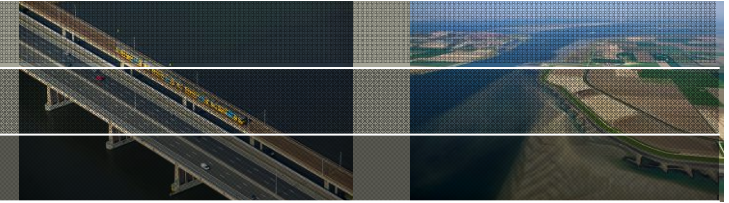

1. Britse BS8006 (1995, update 2010, Engels)
2. Duitse EBGEO (2004, updated 2010, Duits en Engels)
3. Nederlandse CUR design guideline (2010, Nederlands)

1

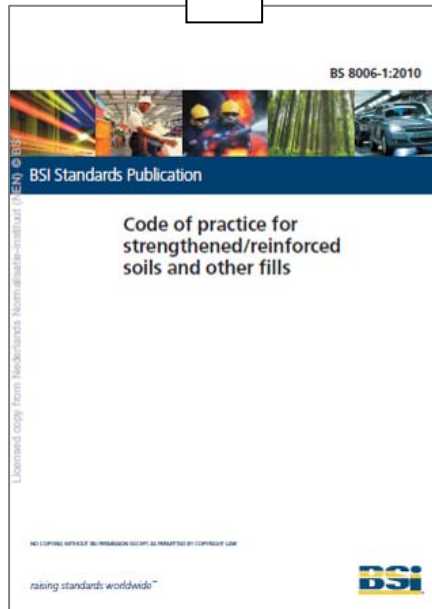

2

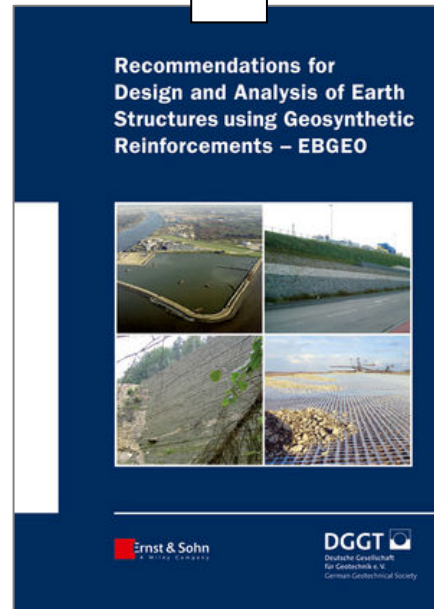

3



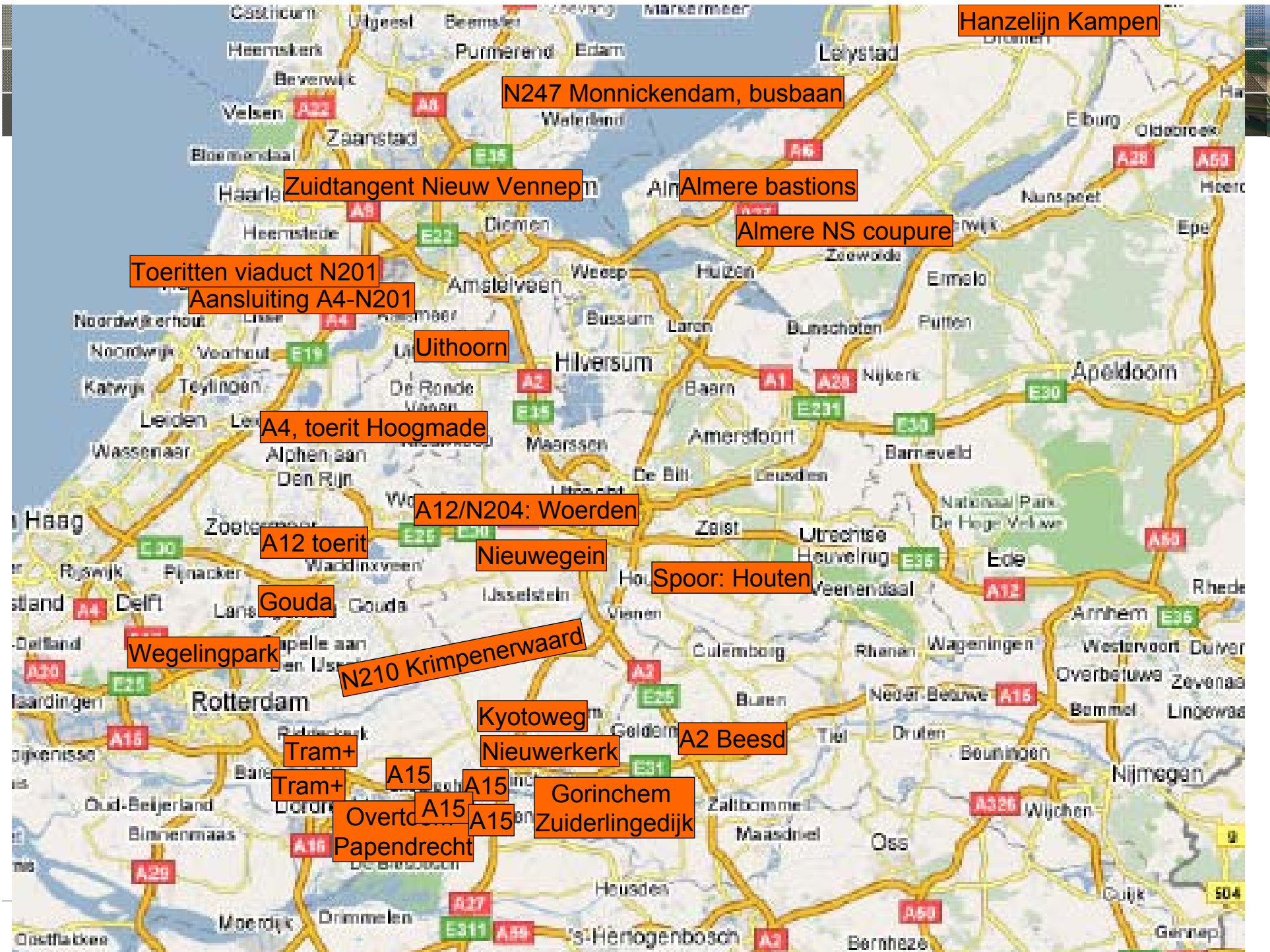

# Kan de CUR-ontwerprichtlijn paalmatrassen beter?

Samenvatting ontwerpregels

Veldmetingen

Doel labproeven

Opzet proeven

Resultaten

Aanpassen ontwerpregels

# Verticale belasting: 2 stappen

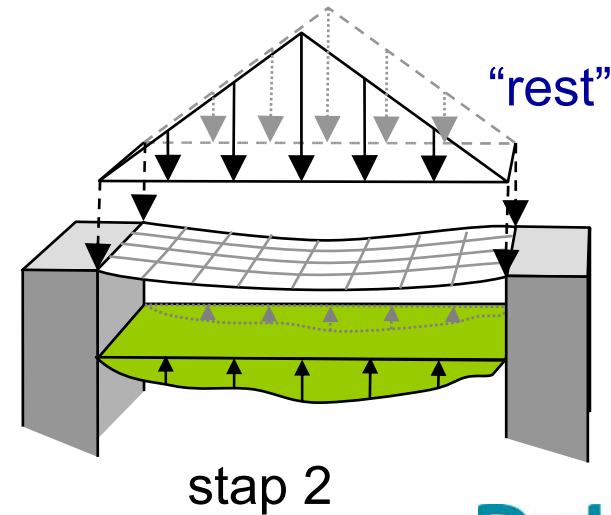
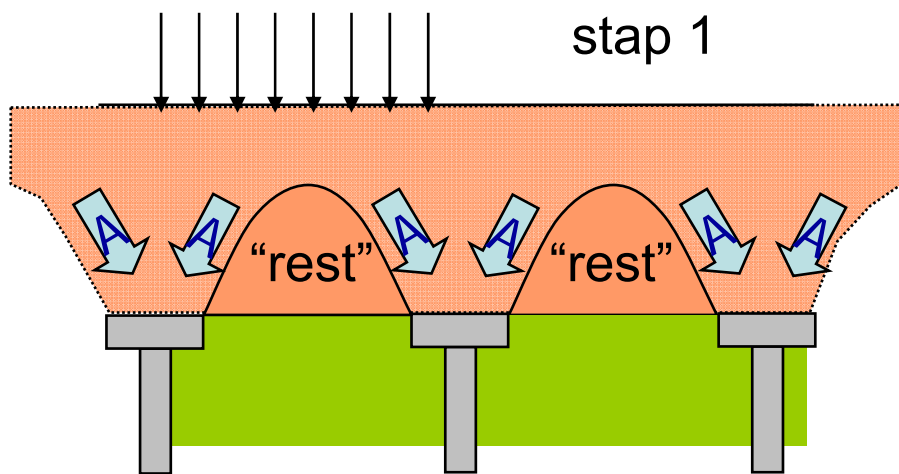
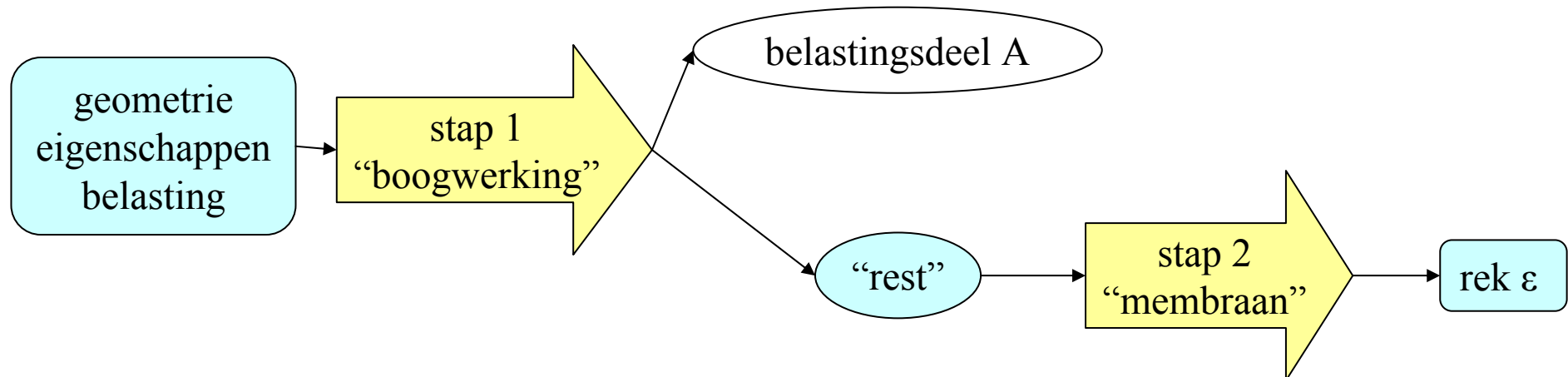
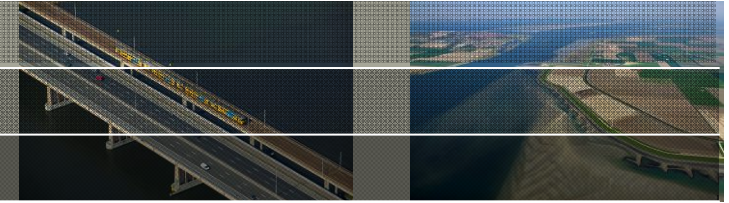

# Definities belastingsverdeling

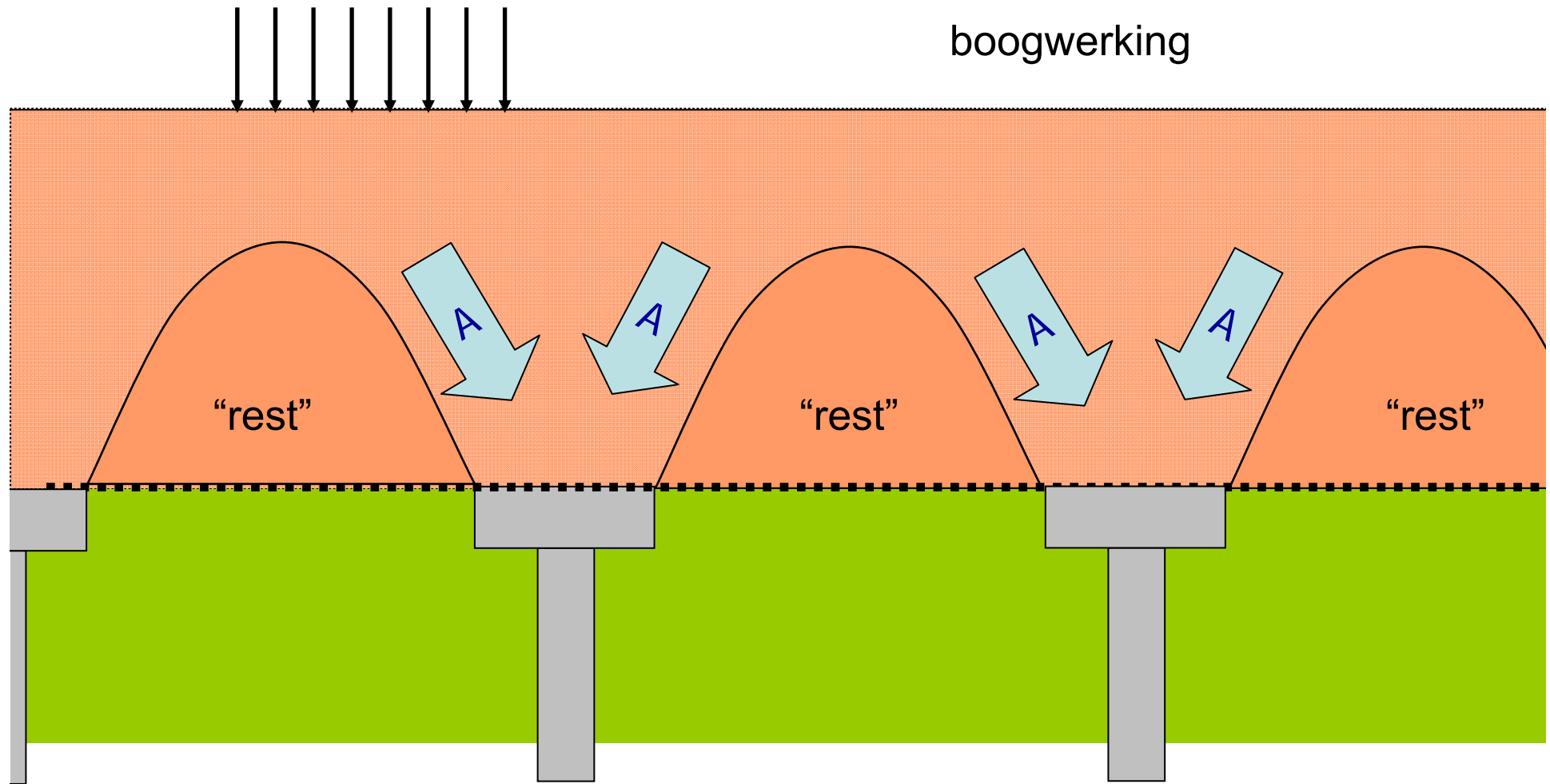
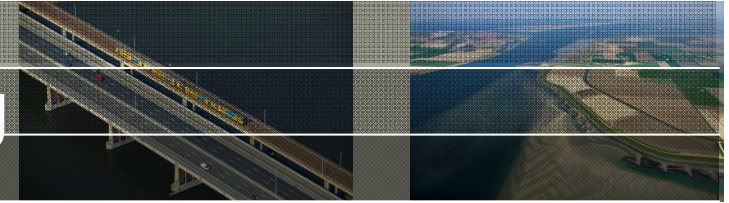

# Definities belastingsverdeling

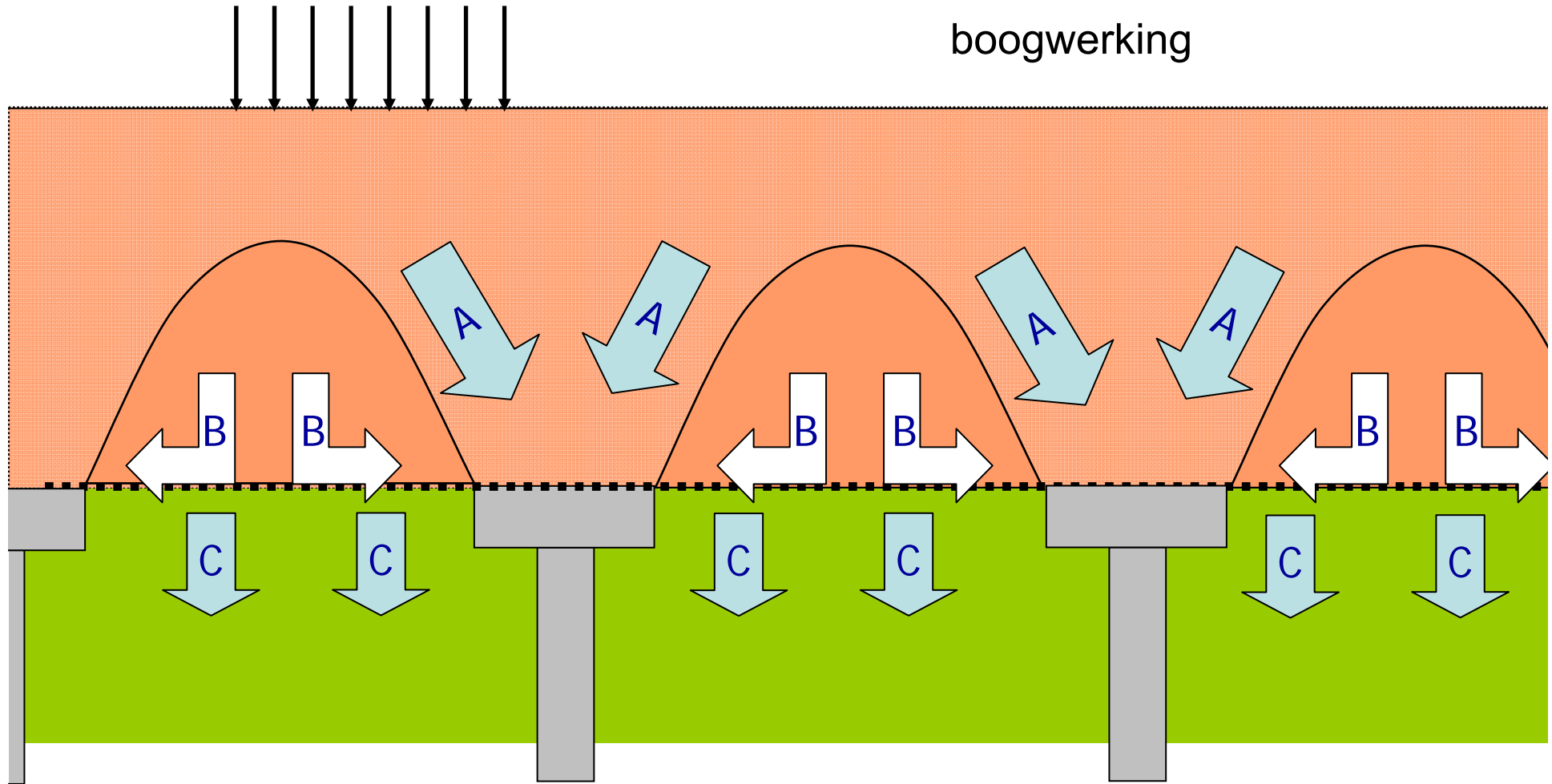
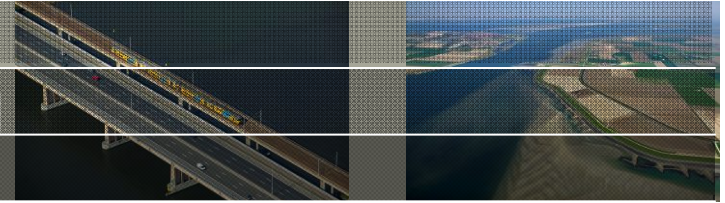



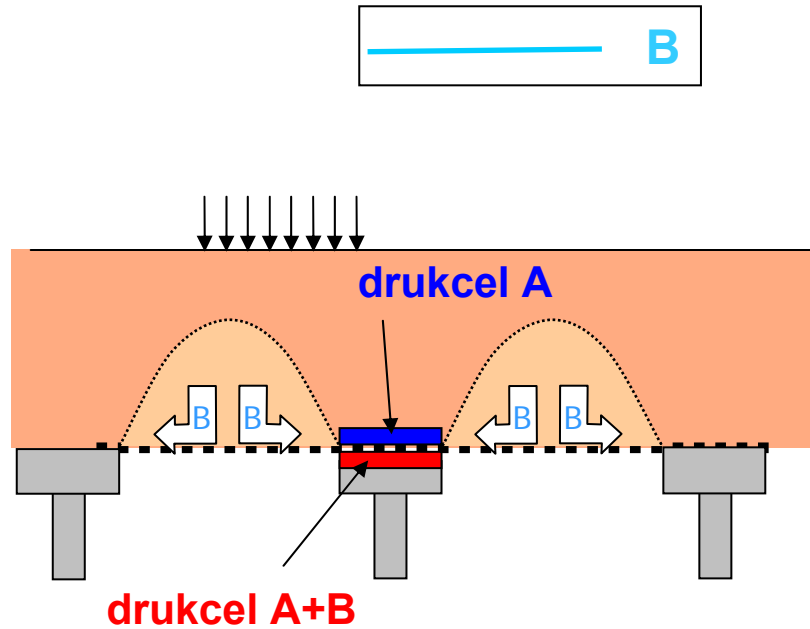

$$B = (A+B) - A$$

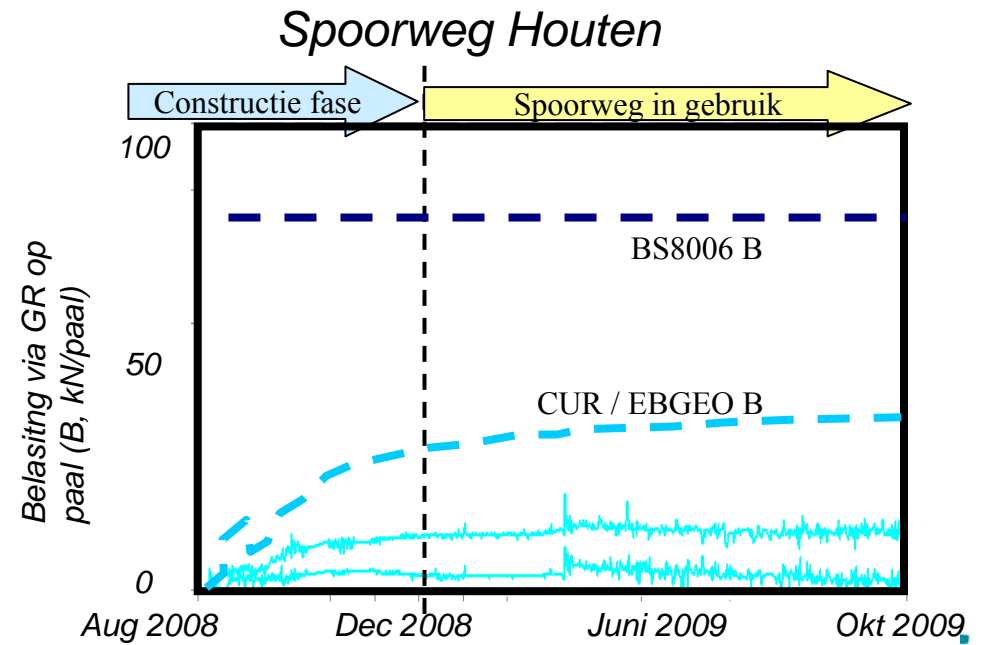
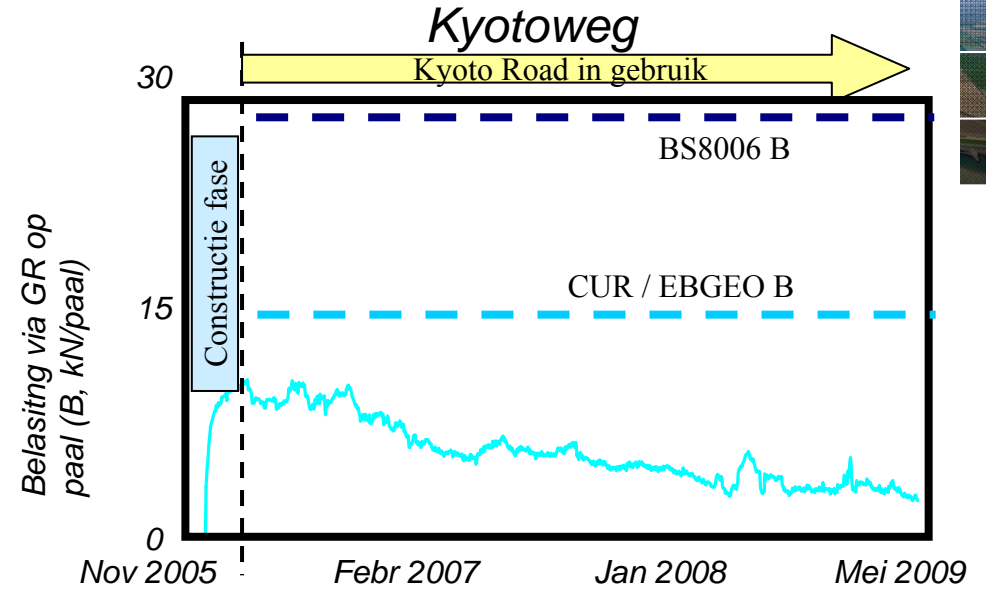

— rek  $\perp$  wegas  
— rek // wegas

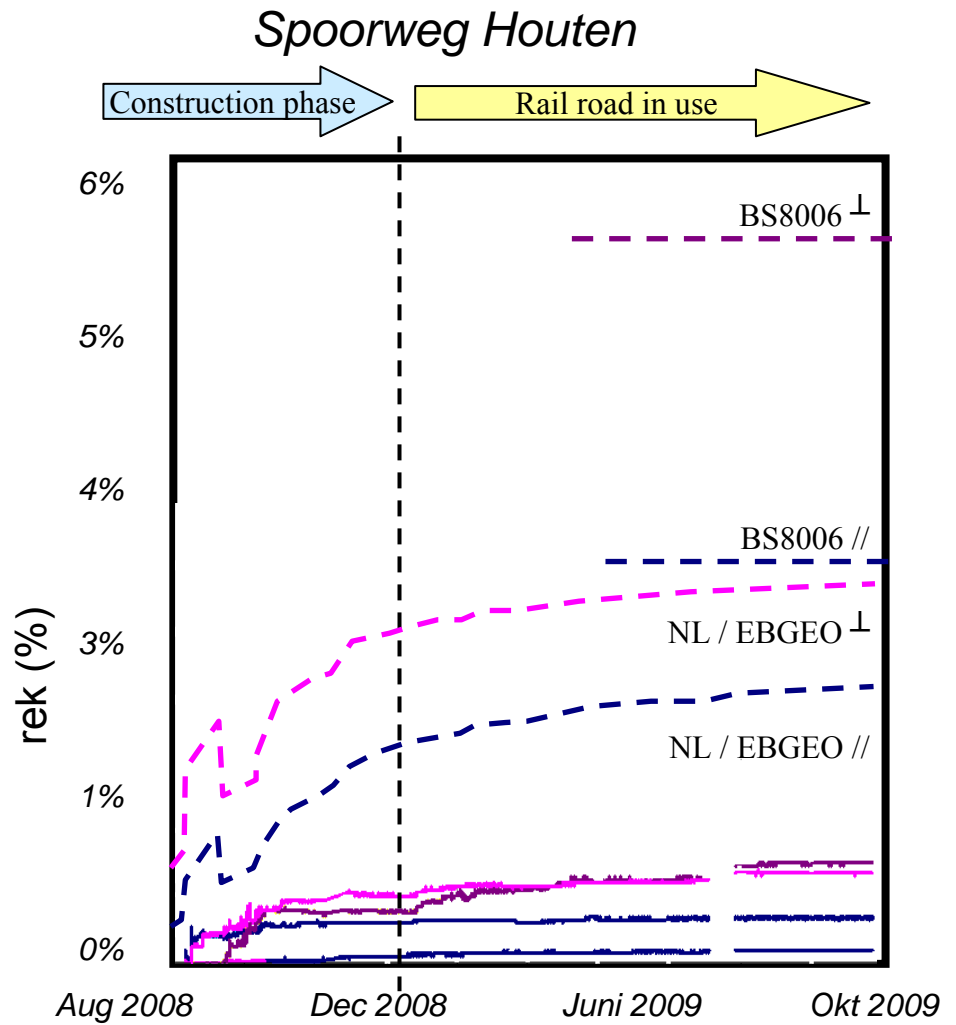
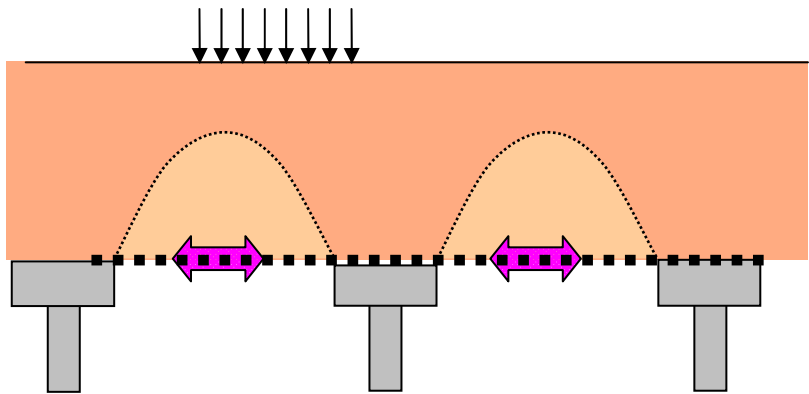

# Proevenserie paalmatrassen

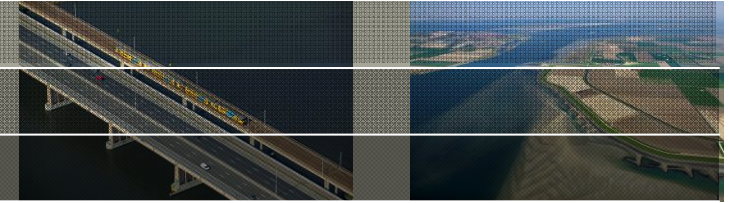

Doel experimenten:

**Het verschil verklaren tussen gemeten en berekende rekken**

1. 3D proeven met granulaat, geokunststof en realistische spanningen
2. Stap 1 en 2 apart valideren
3. Variaties

Noodzakelijk: A, B en C apart meten

# Paalmatrasproeven

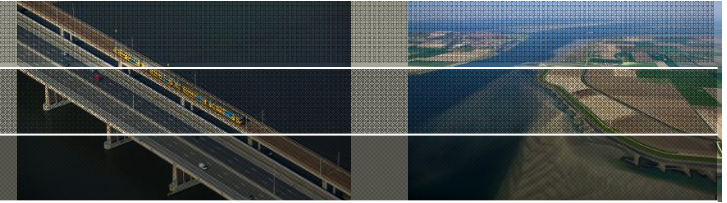

Samenvatting ontwerp

Veldmetingen

Doel labproeven

Opzet proeven

Resultaten

Aanpassen model

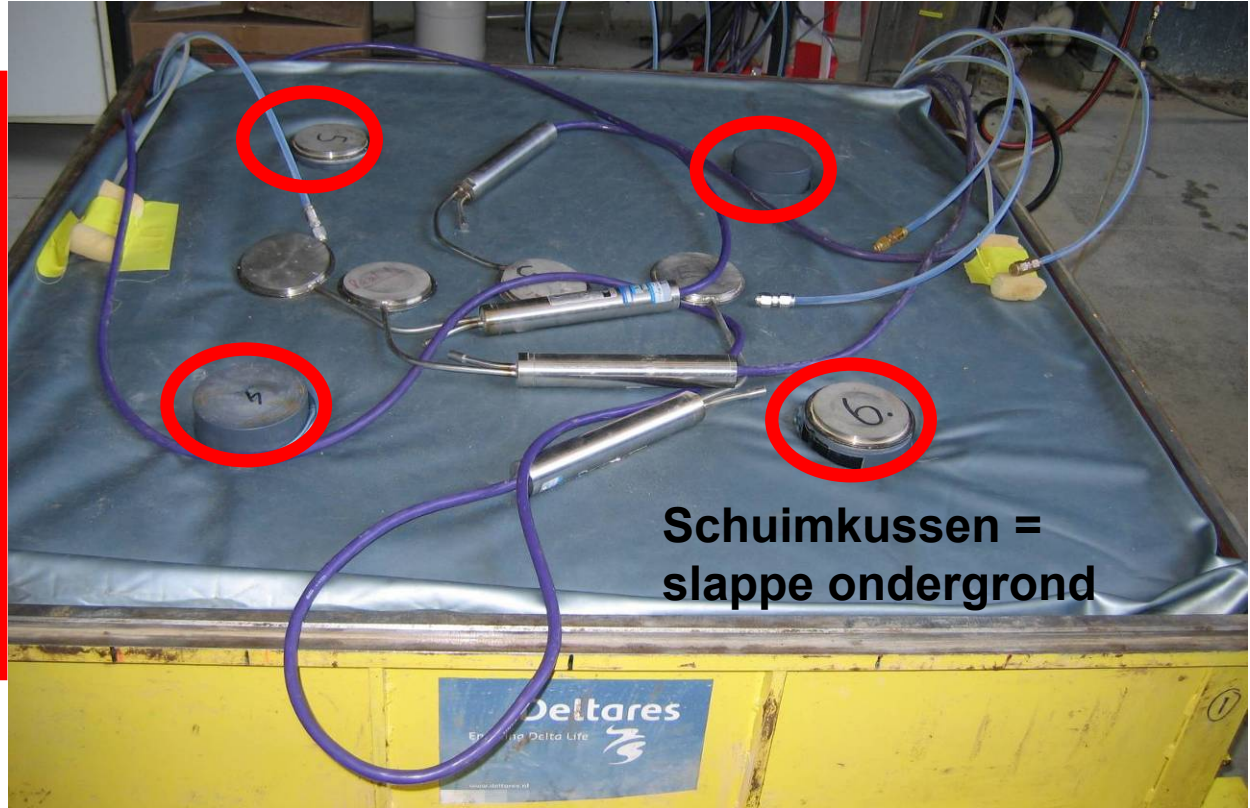
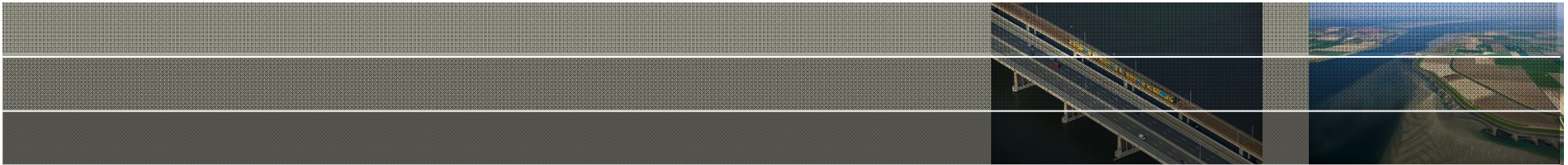

Schuimkussen =  
slappe ondergrond

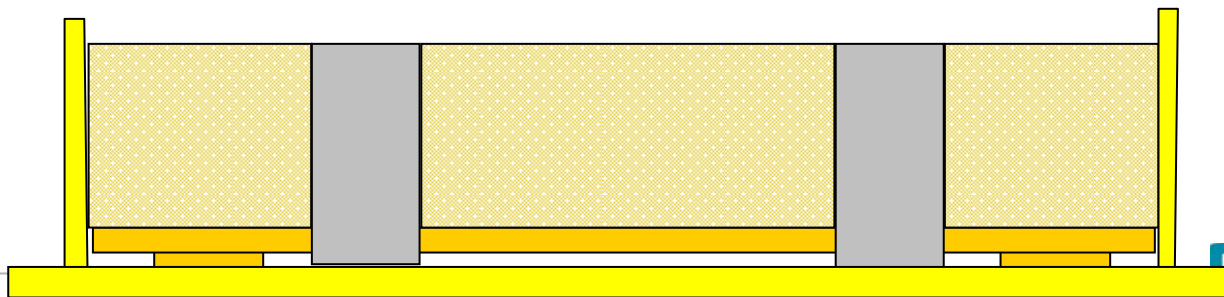

Deltares

27 november 2011

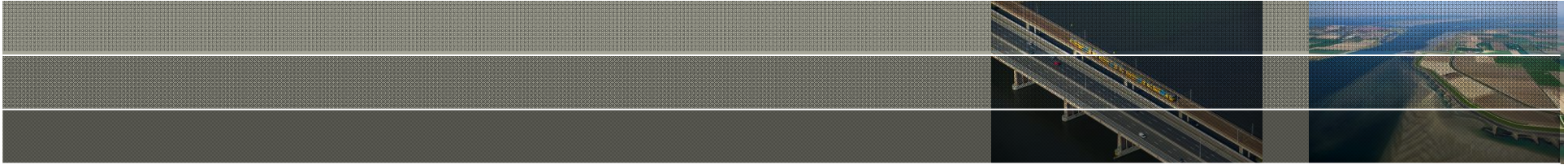

Deltares

27 november 2011

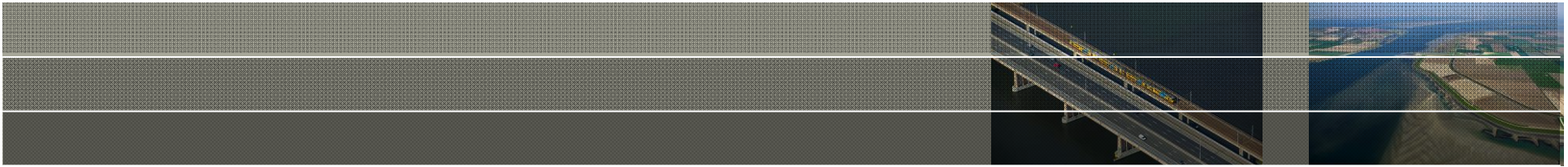

**Deltares**

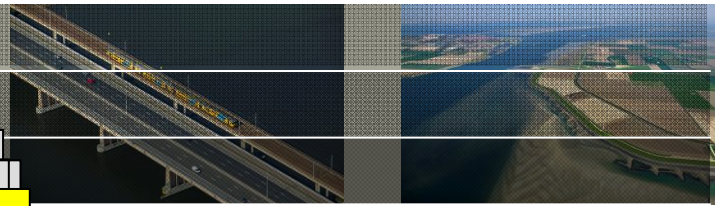
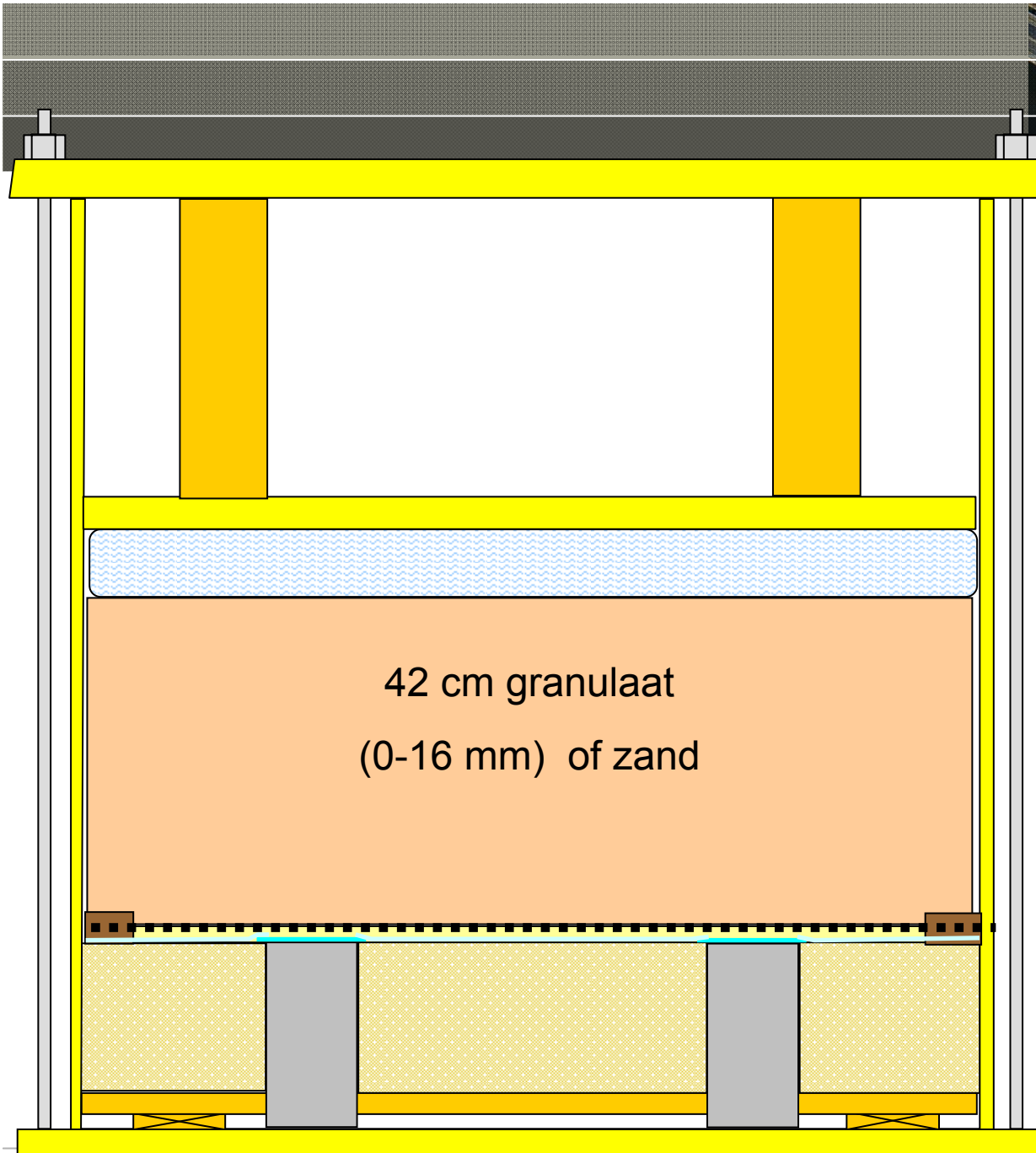

27 november 2011



# Test procedure

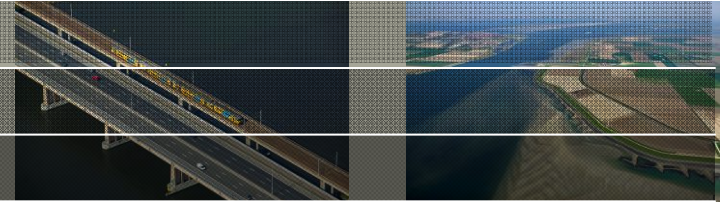

Consolidatie

Bovenbelasting → 25 kPa

Consolidatie

Consolidatie

Consolidatie

Bovenbelasting → 50 kPa

Consolidatie

Consolidatie

Consolidatie

Bovenbelasting → 75 kPa

Consolidatie

Consolidatie

Consolidatie

Bovenbelasting → 100 kPa

Consolidatie

Consolidatie

Vacuum

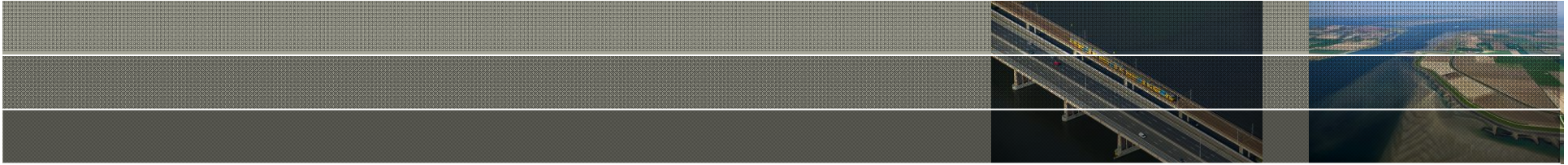

27 november 2011

**Deltares**

# Metingen

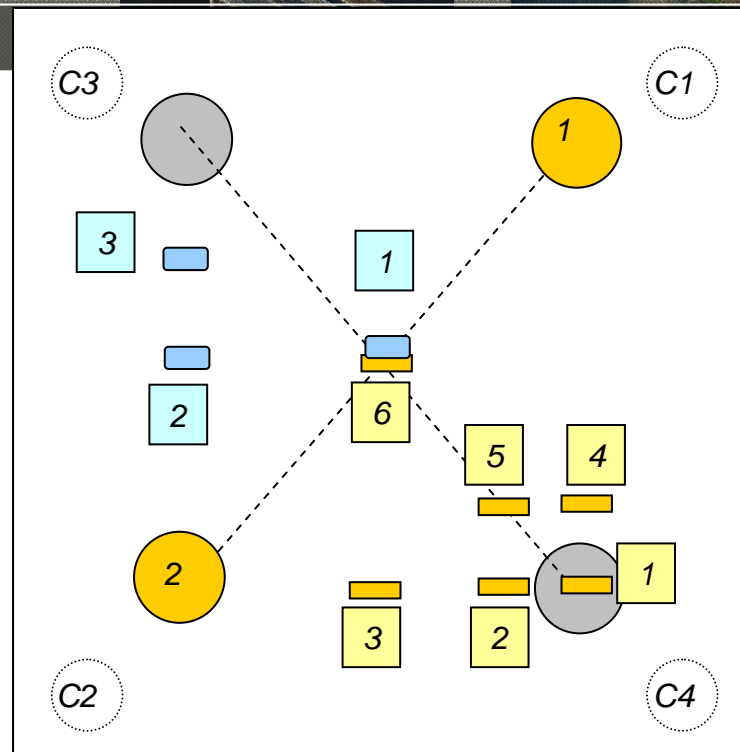
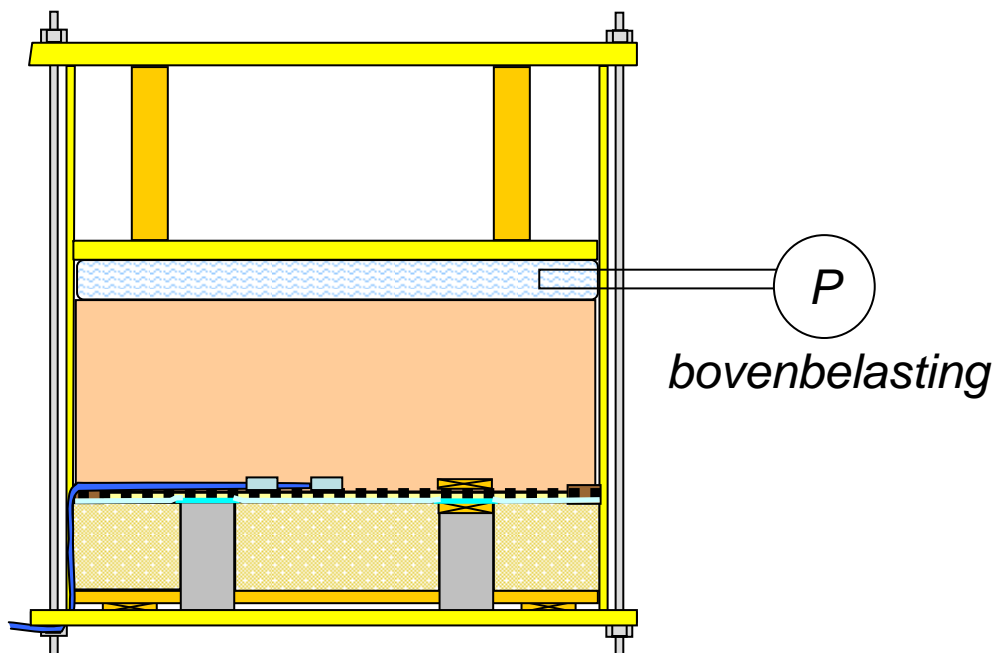
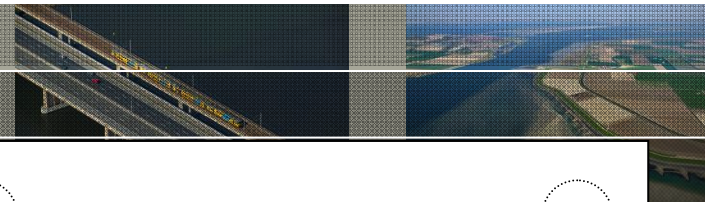

Belastingsverdeling

Verticale verplaatsing GR

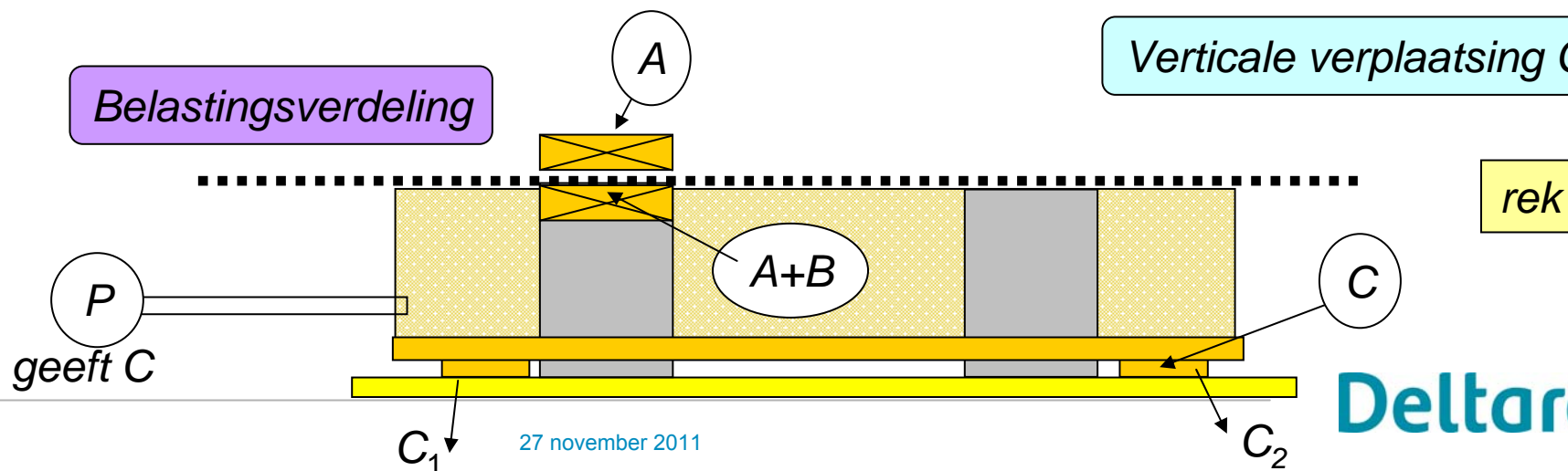

27 november 2011

Deltares

# Paalmatrasproeven

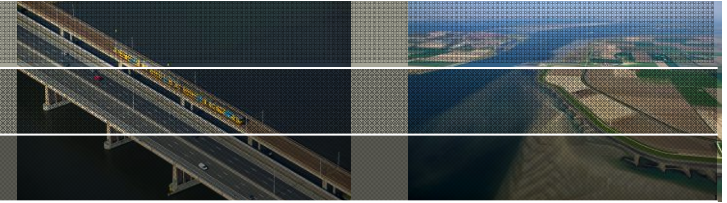

Samenvatting ontwerp

Veldmetingen

Doel labproeven

Opzet proeven

Resultaten

Aanpassen model

# Resultaten

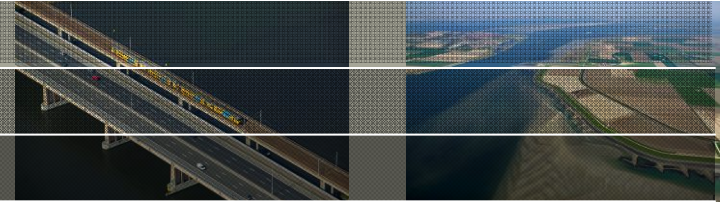

Karakteristieke resultaten

Vergelijking met het CUR/EBGEO ontwerpmodel

1. Stap 1 (boogwerking)
2. Stap 2 (membraan)

Suggesties voor aanpassingen ontwerpmodel

# Resultaten

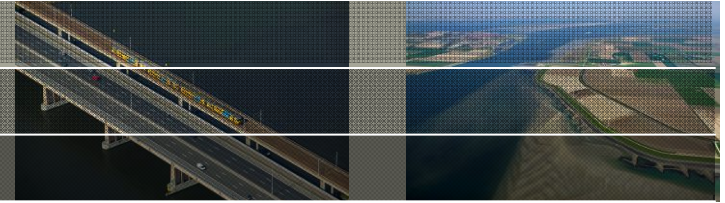

Karakteristieke resultaten

Vergelijking met het CUR/EBGEO ontwerpmodel

1. Stap 1 (boogwerking)
2. Stap 2 (membraan)

Suggesties voor aanpassingen ontwerpmodel

# Karakteristieke resultaten

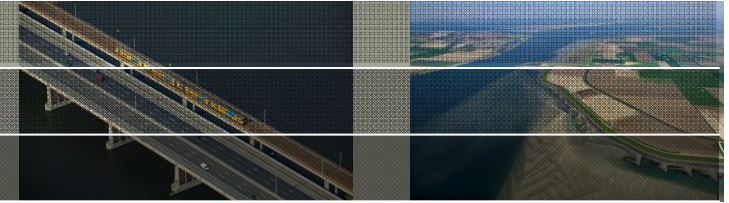

Representatieve proef:

(1 GR laag:  
2 lagen of Huesker  
Fortrac 110/25MP  
op 1 frame)

42 cm granulaat  
(0-16.5 mm),  
 $\varphi_{\text{peak}} = 49.0^\circ$ ,  
 $\psi = 9^\circ$

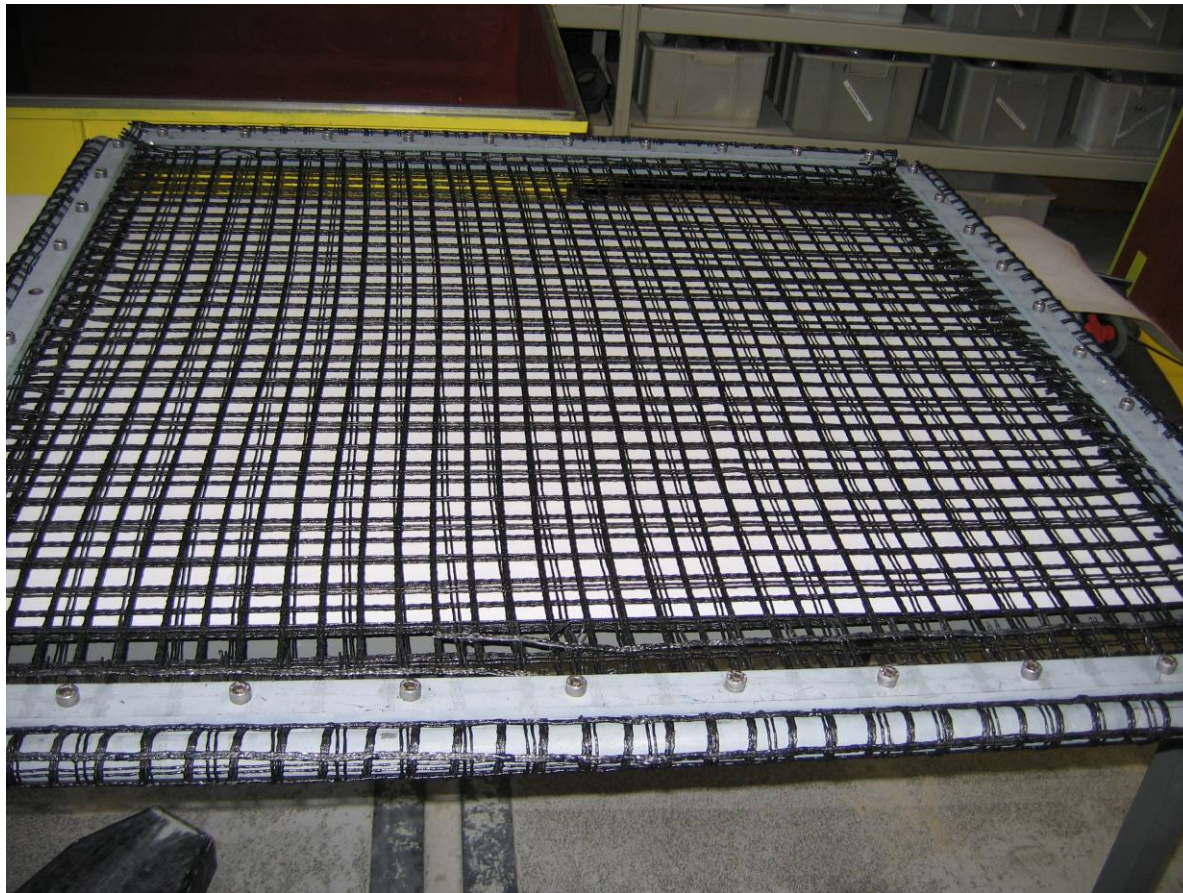

# Stap 1

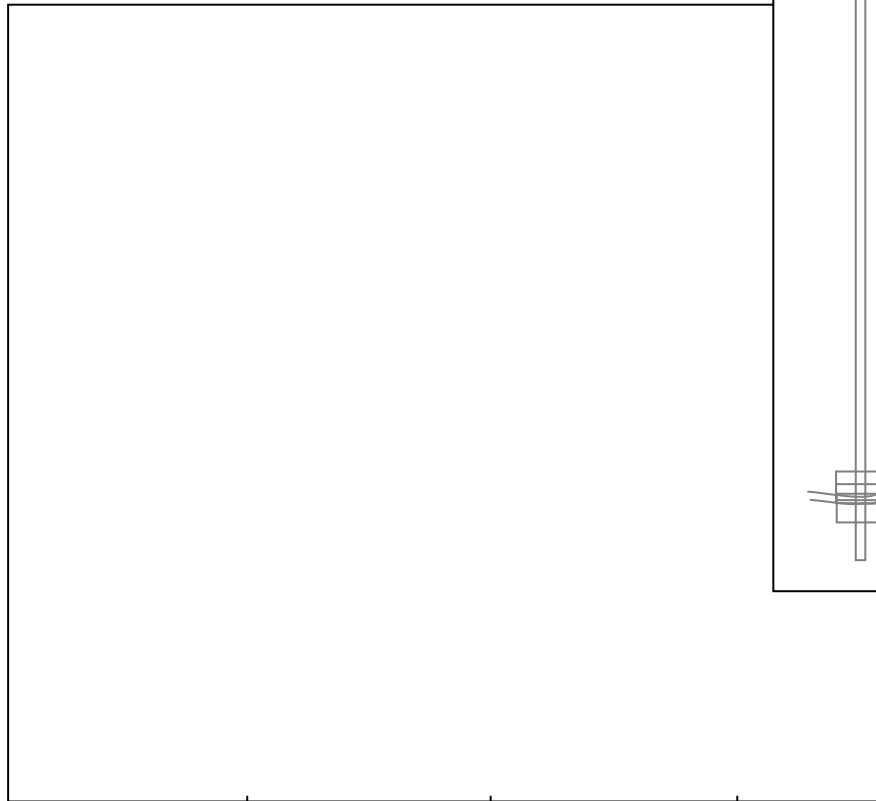

5 10 15

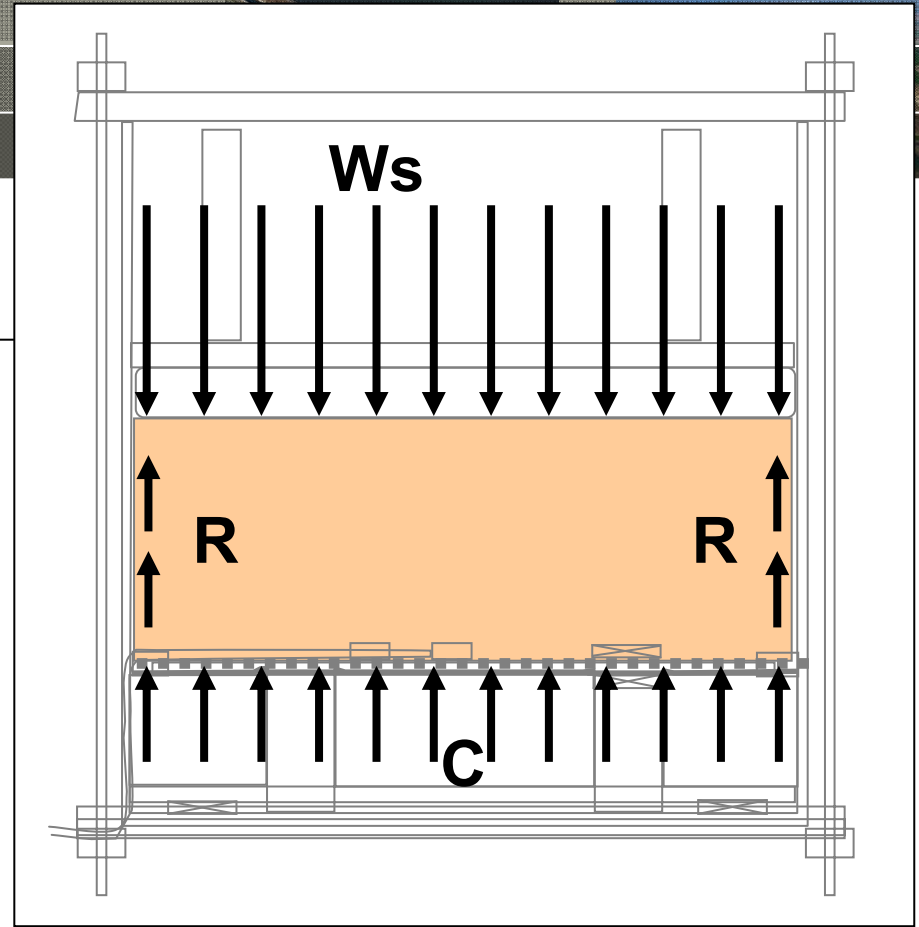

Netto belasting op aardebaan (kN/paal) =  $W_s - R - C$



# Stap 1

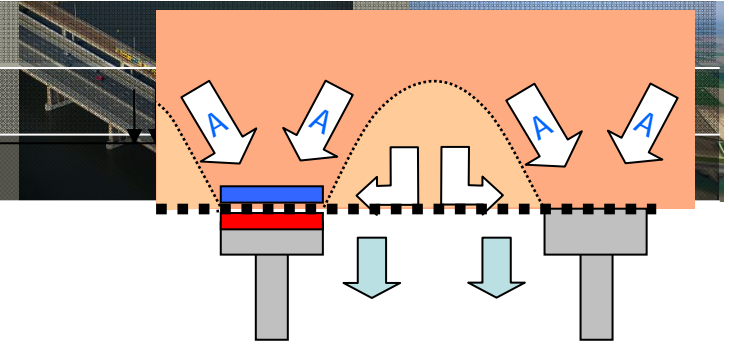

Twee types belasting

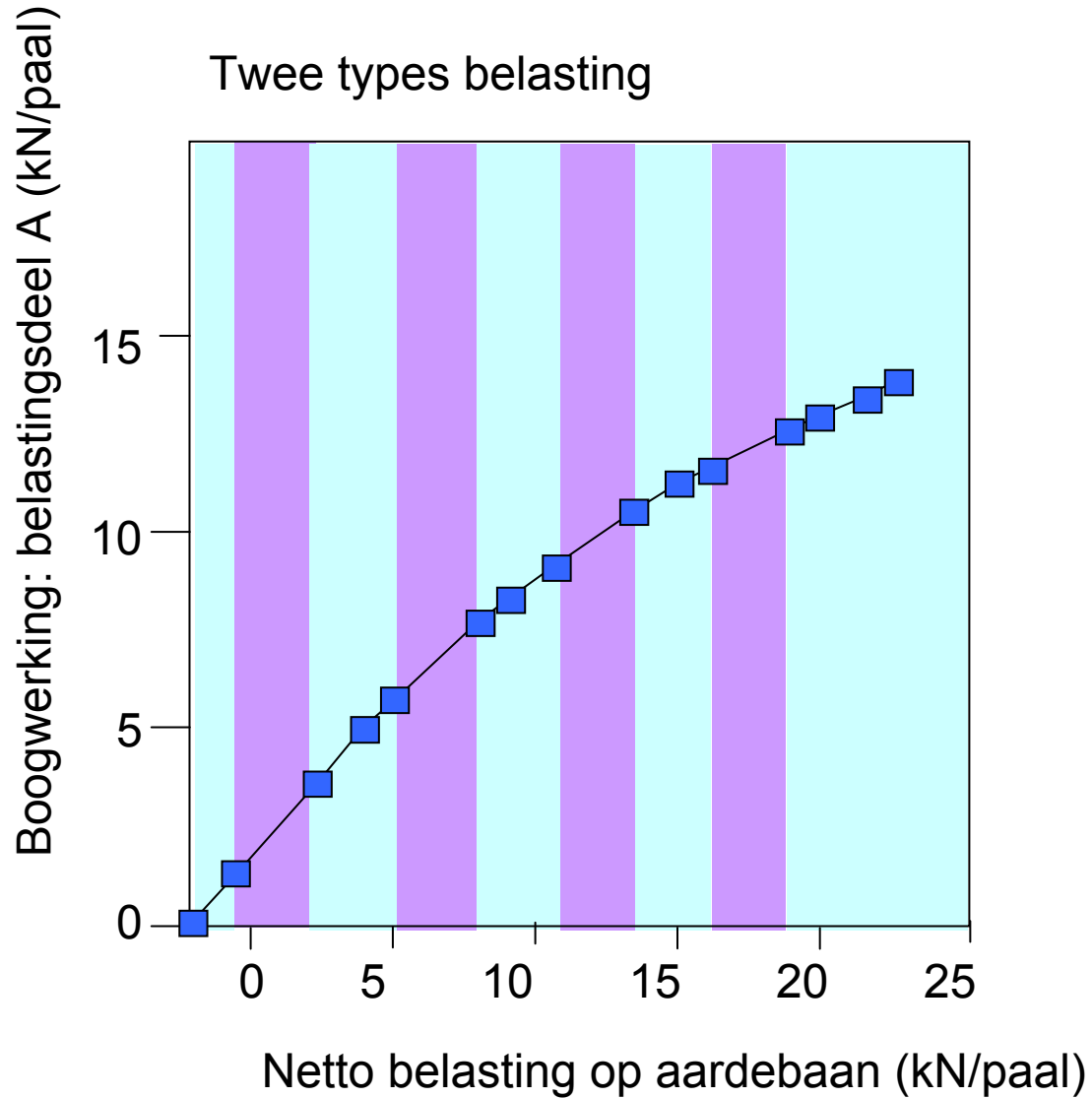

Consolidatie  
schuimkussen  
(ondergrond)

Toename  
bovenbelasting

duidelijke relatie  
netto belasting en A

consolidatie =  
toename boogwerking

# Stap 1

- ✗ Relatie netto belasting en A
- ✗ Consolidatie geeft toename boogwerking (toename A)

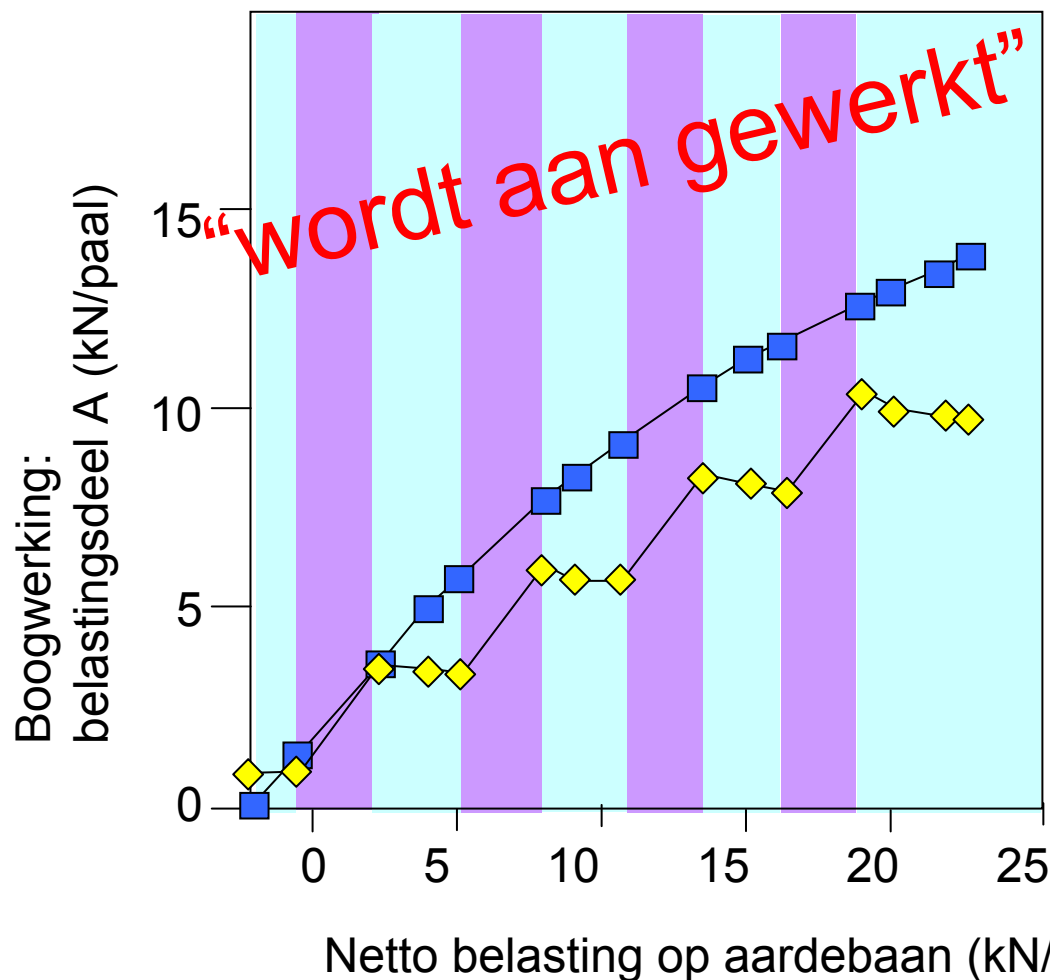
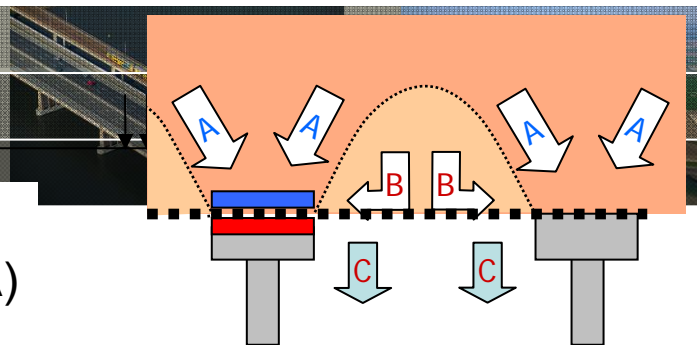

Consolidatie  
schuimkussen  
(ondergrond)

Toename  
bovenbelasting

■ gemeten A kN/paal  
◆ berekende A kN/paal

## Stap 2

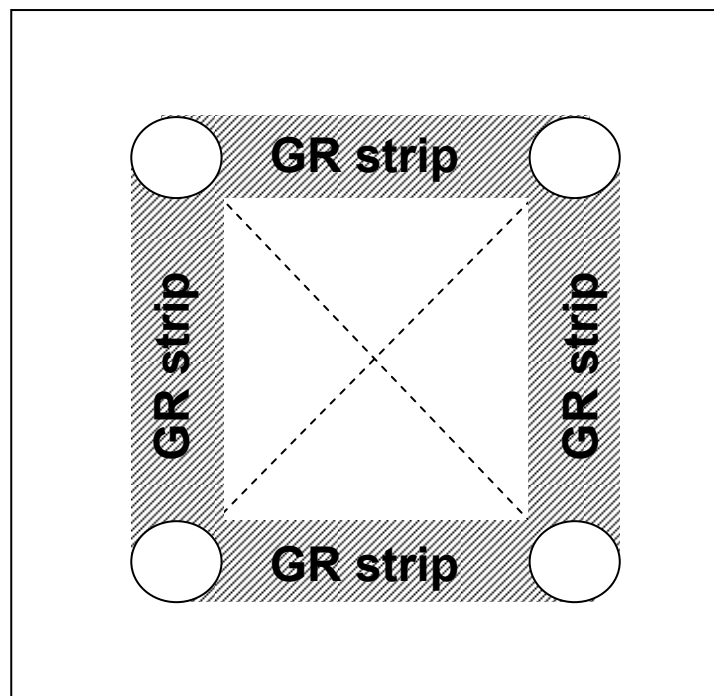
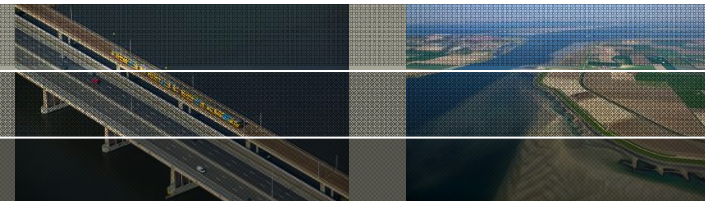

Rekken hoofdzakelijk in de GR strippen

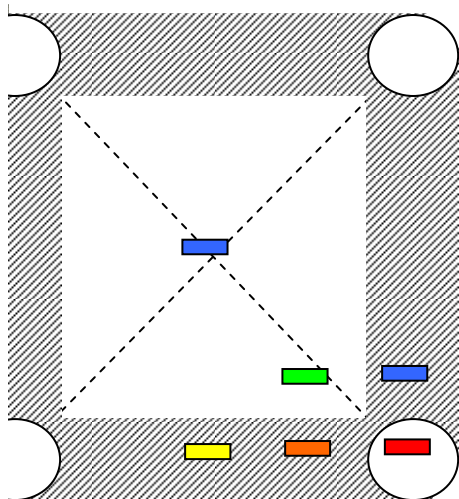

## Stap 2

Rekken hoofdzakelijk in GR strippen

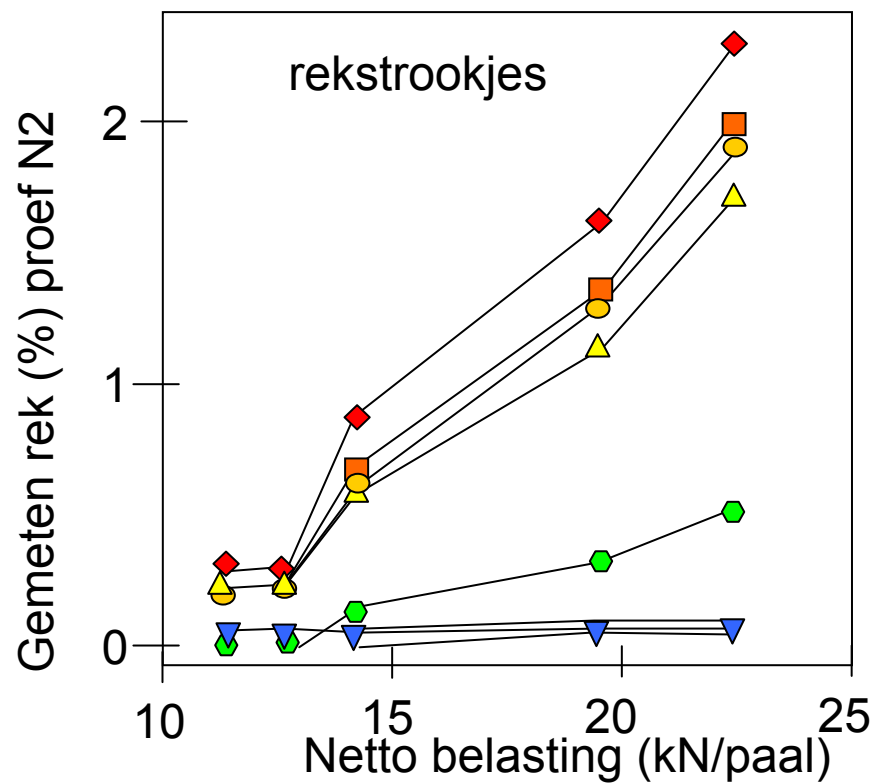
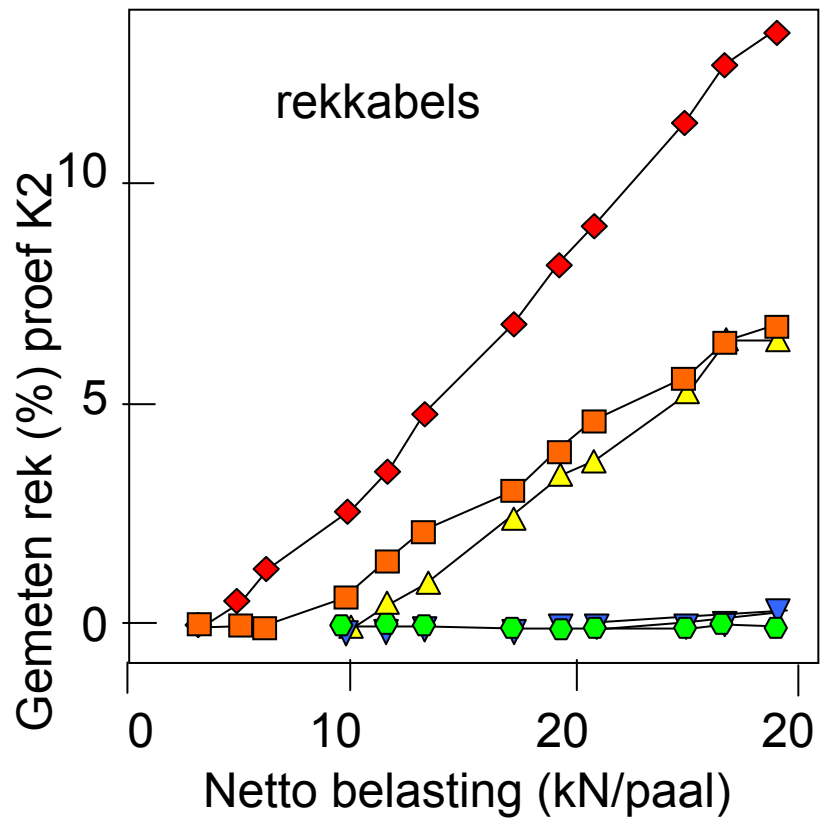
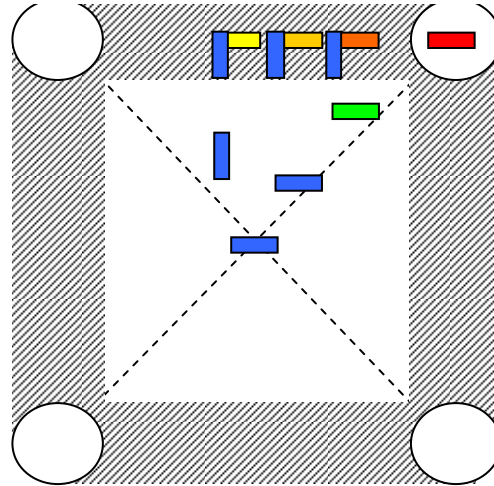

## Stap 2

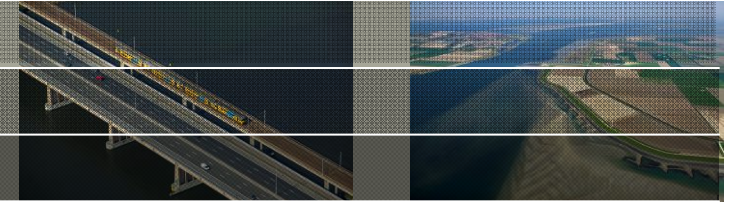

Grootste rekken: op paal

→ voor deze gladde, kleine diameter palen

Op een na grootste rekken: in GR strippen

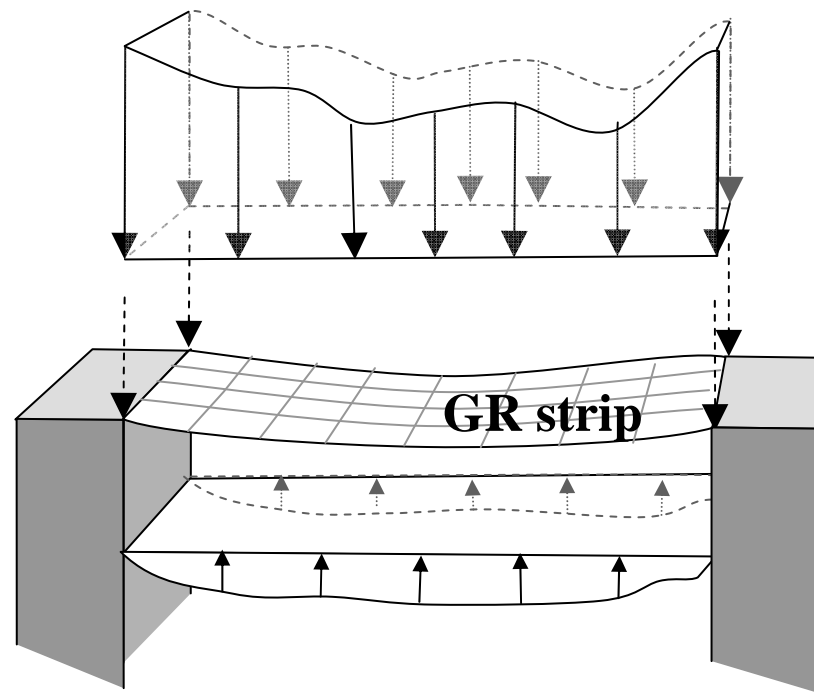

# Stap 2

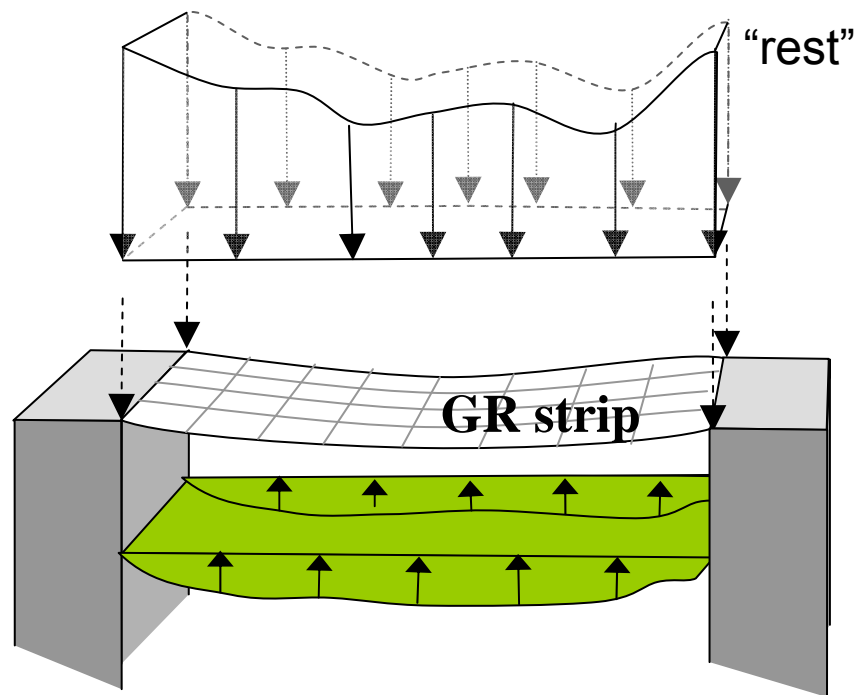
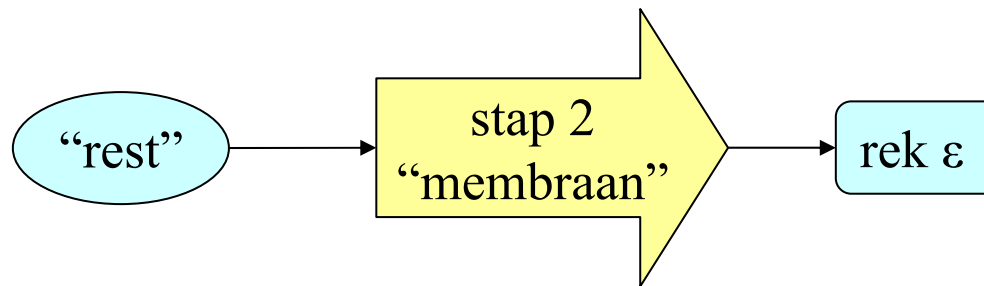
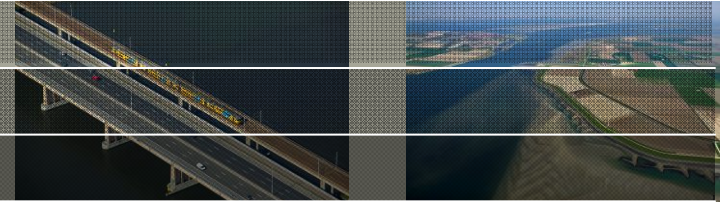

belastingsverdeling



vervorming GR

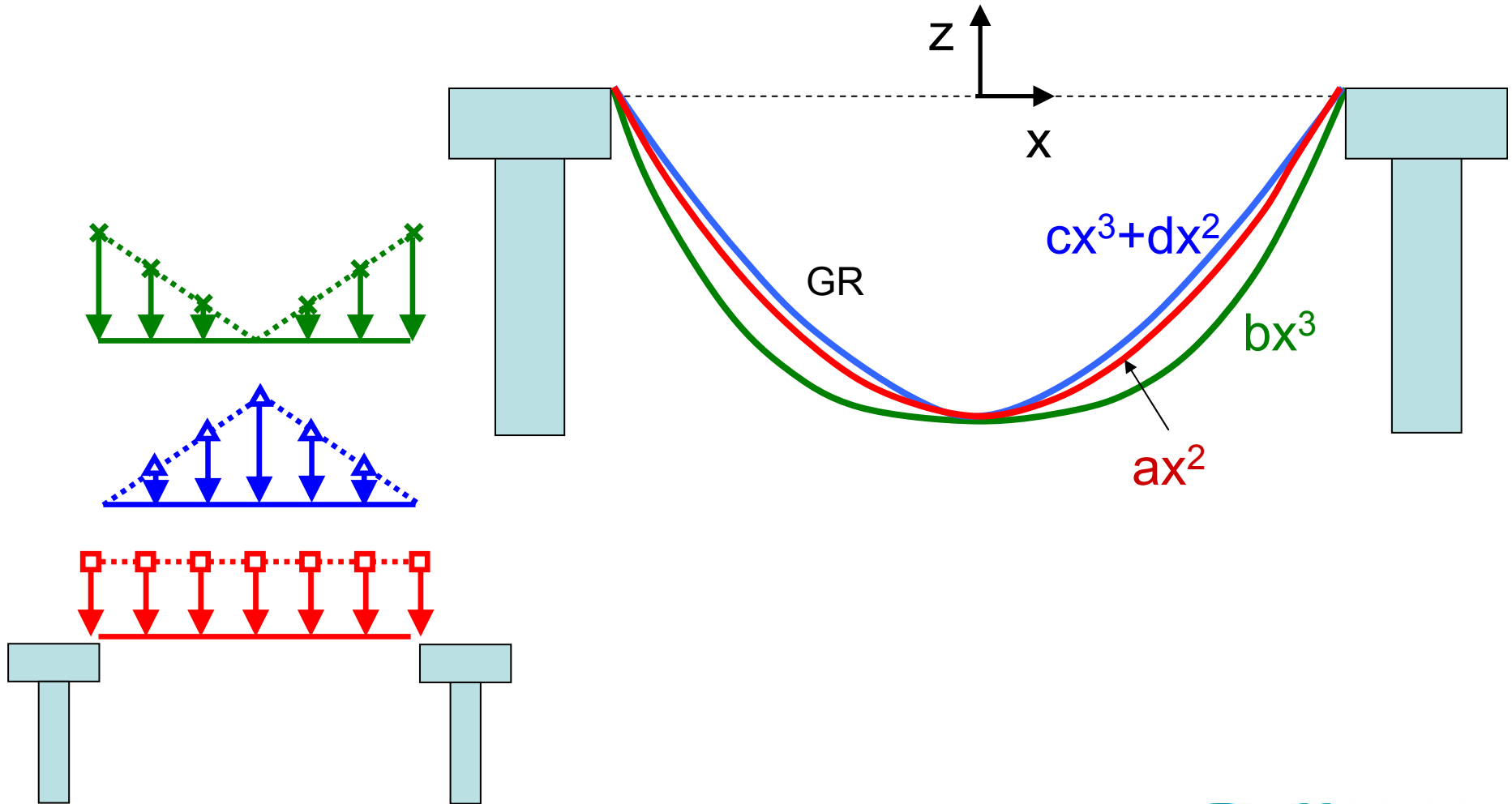

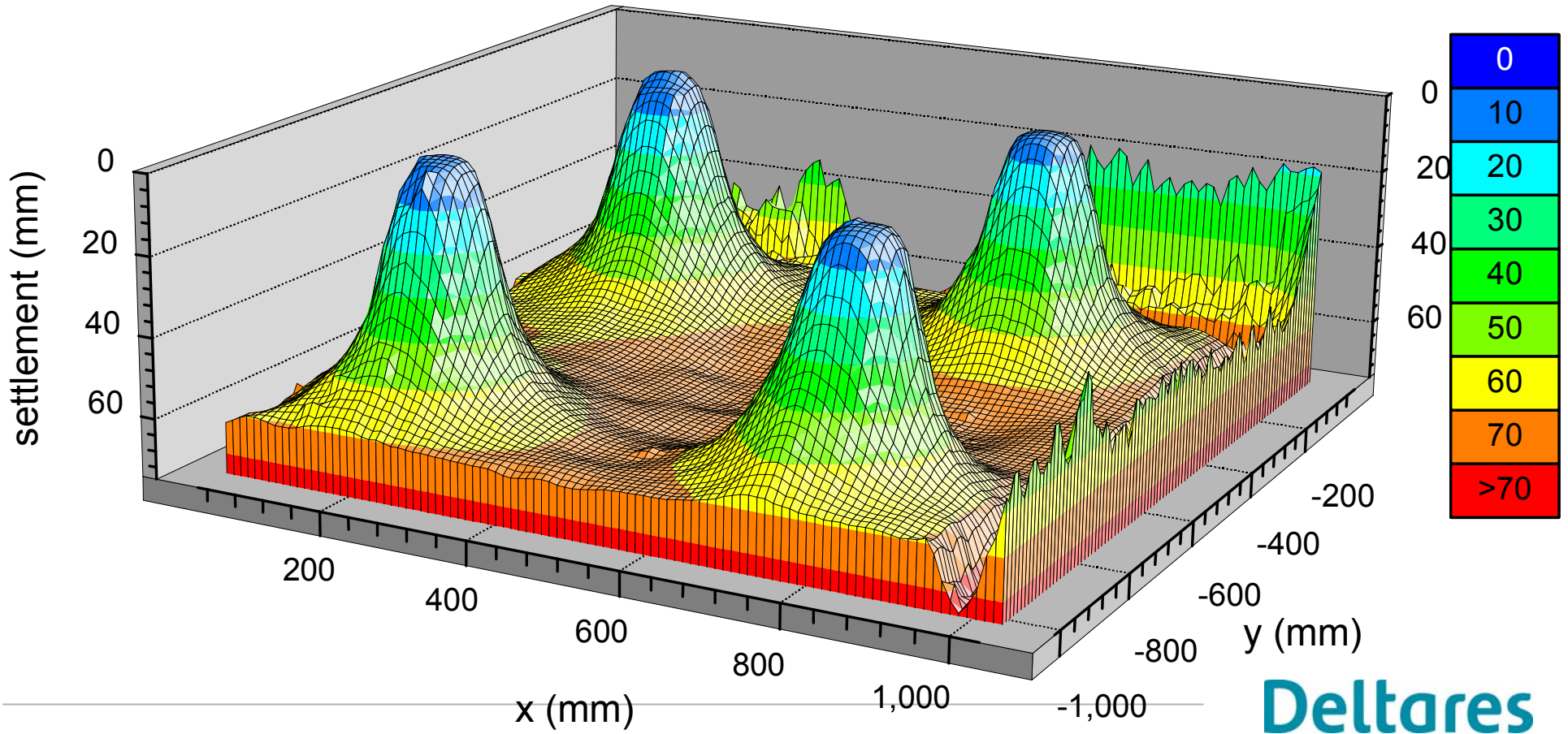
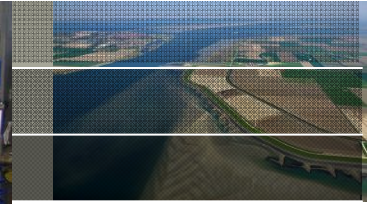

27 november 2011

Deltares



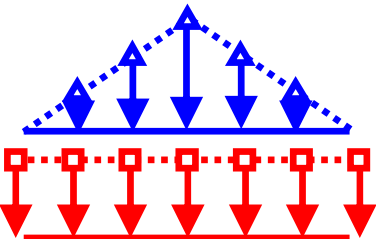
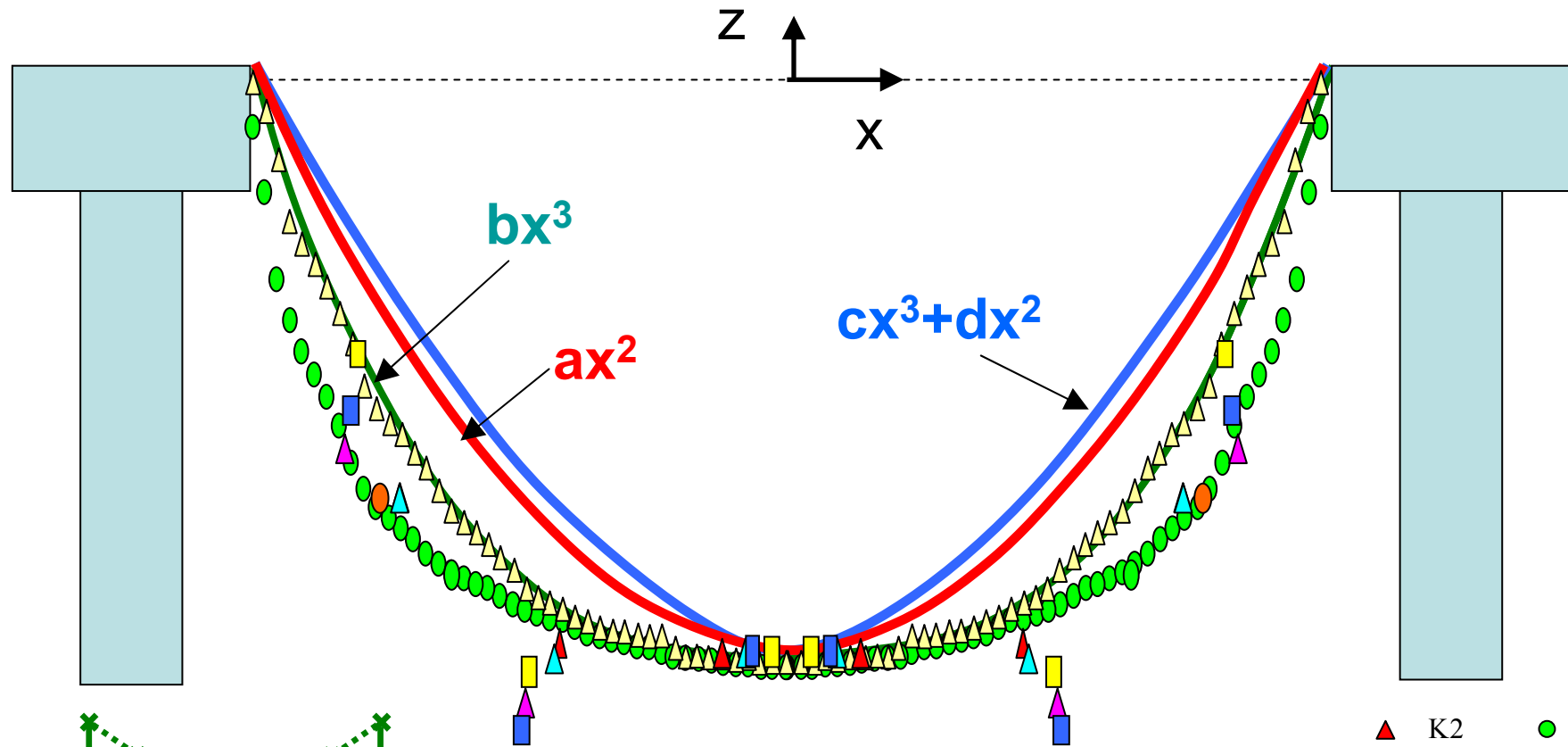

- ▲ K2
- K3
- K4
- K5
- ▲ K6
- K7
- ▲ K8

(eind situatie,  
minimale of geen  
ondersteuning  
ondergrond)

# Situaties voor het einde van de proeven

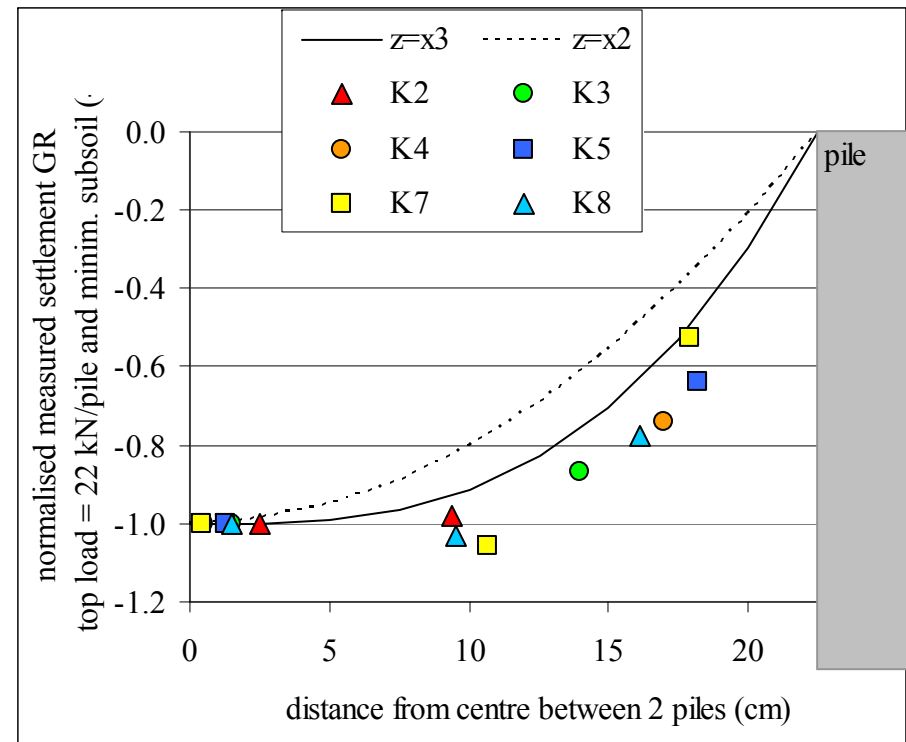
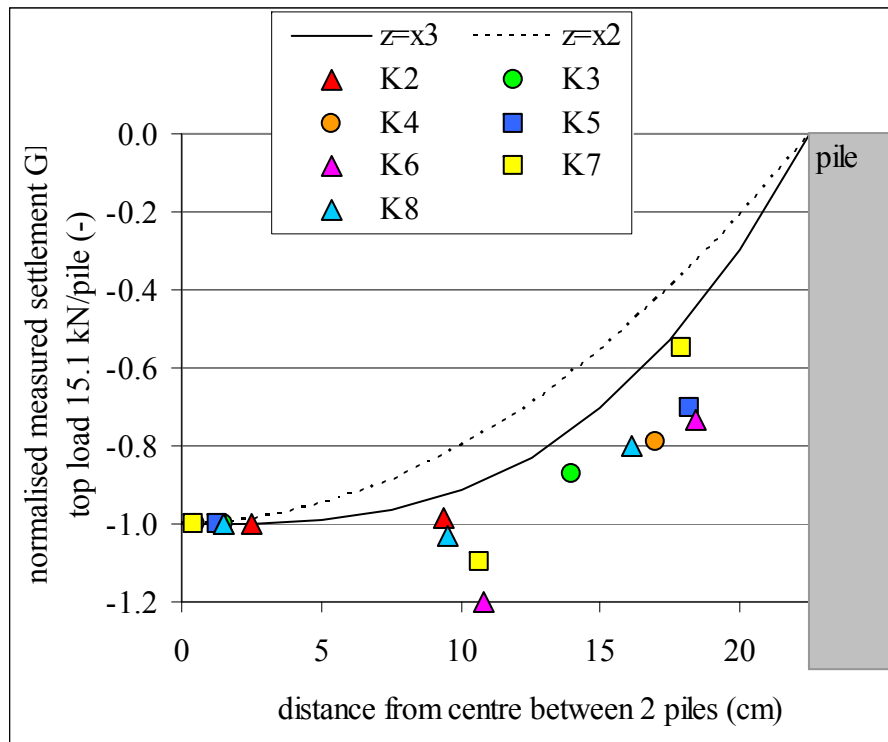

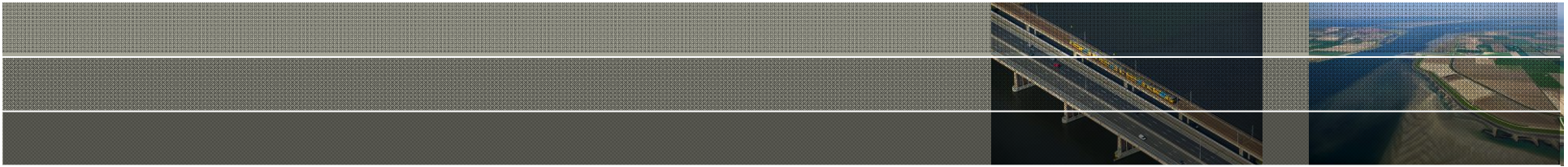

## Conclusie:

Vervormd GR is minstens  $GR = ax^3$  (derde orde polynoom of meer)

En dus is de belastingsverdeling minstens een inverse driehoek)

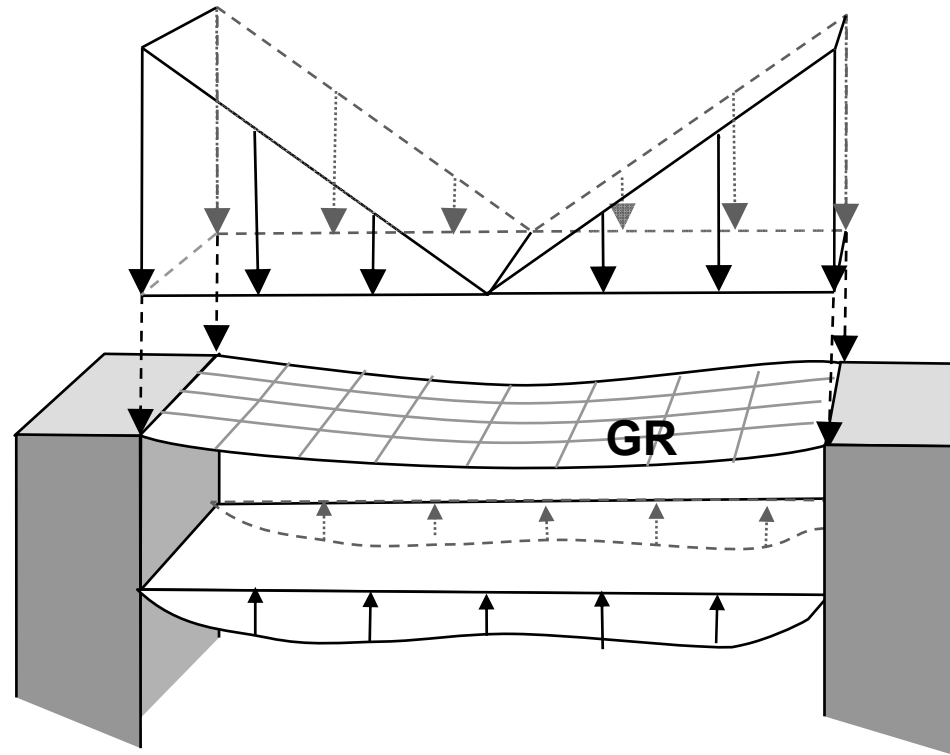

Geconcludeerd uit  
vervorming GR.

Nieuwe serie proeven:  
meting van  
belastingsverdeling

# Gemeten *belastingsverdeling* in aanvullende proeven

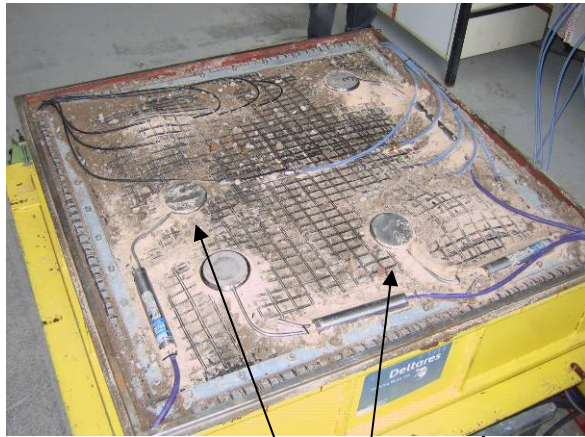

extra  
opnemers

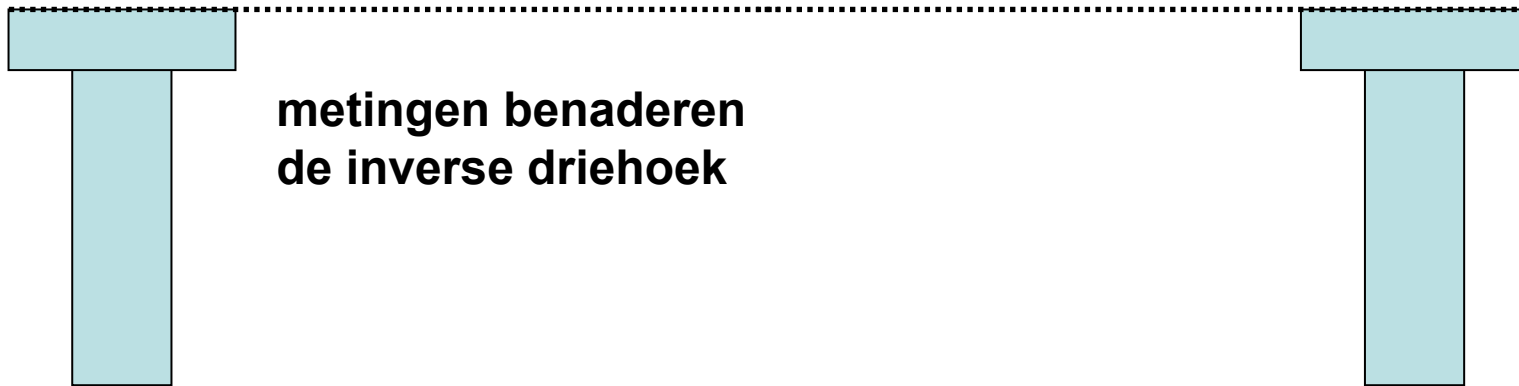
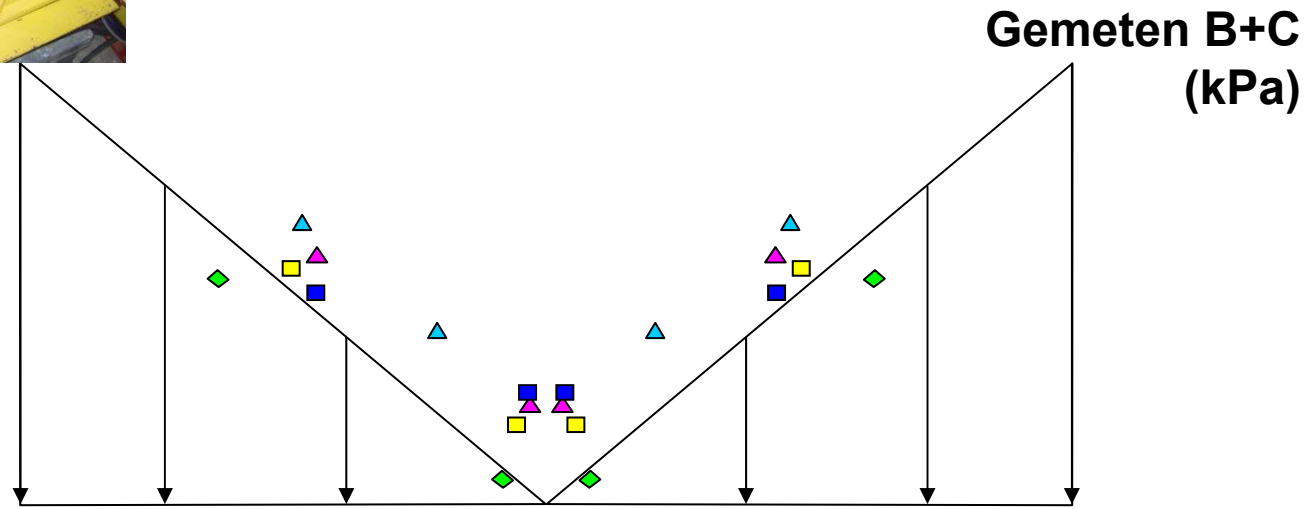

# Eindige elementen

Narekenen proef met  
Plaxis 3D Tunnel  
(Theresa den Boogert,  
nu Mobilis)

Praktijkvoorbeeld van  
Marco Peters (Grontmij)

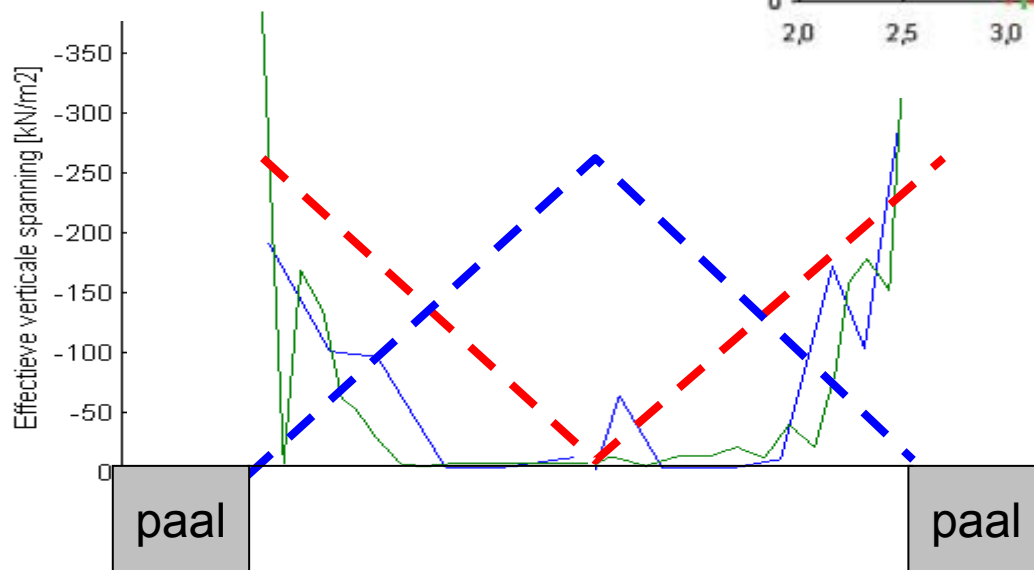
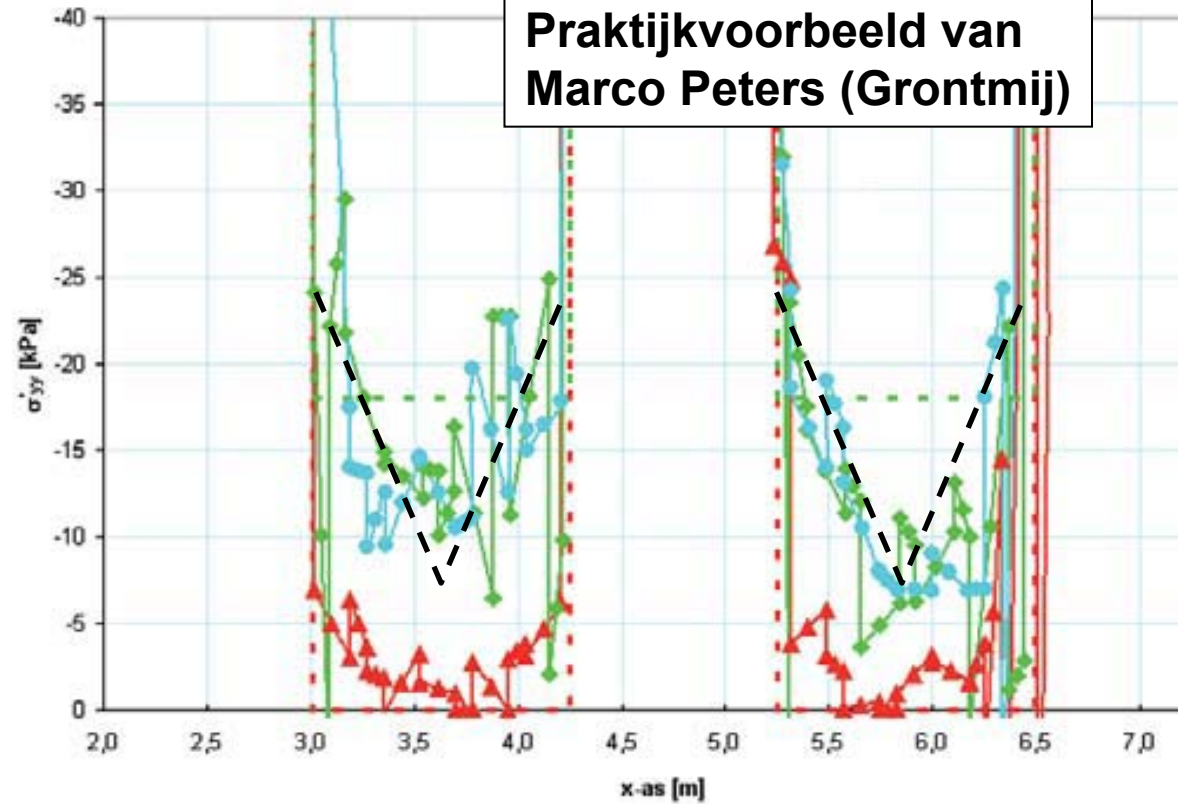

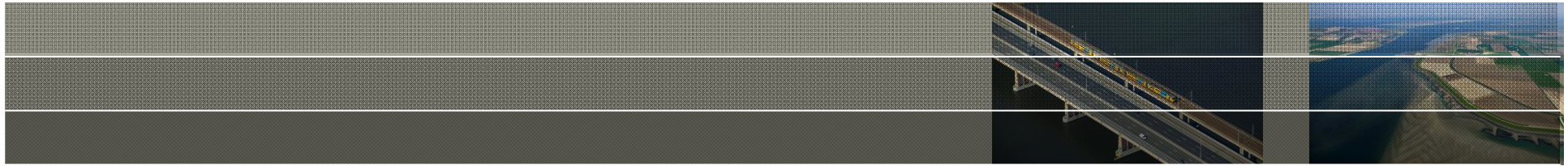

Conclusies tot nu toe (stap 2):

4. Rekken vooral in GR strippen
5. Belastingsverdeling: inverse driehoek

# Paalmatrasproeven

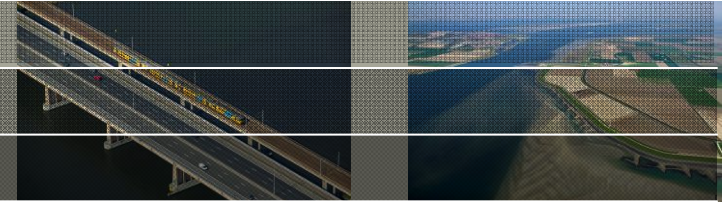

Samenvatting ontwerp

Veldmetingen

Doel labproeven

Opzet proeven

Resultaten

**Aanpassen model**

# Vergelijking rekenmodel en metingen



Stap 2:

Twee aanpassingen:

- belastingsverdeling
- ondergrond



# Het effect van:

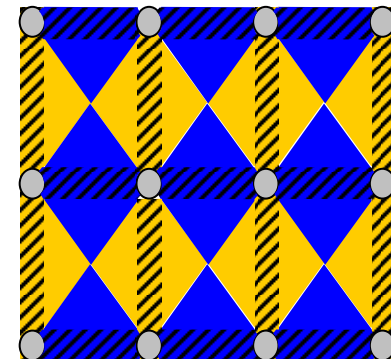
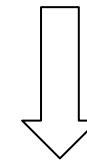
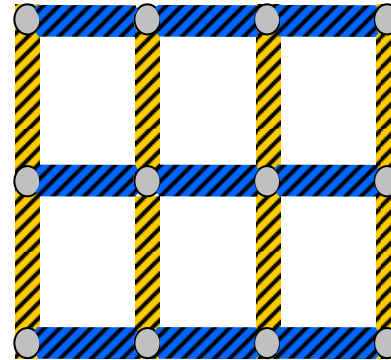
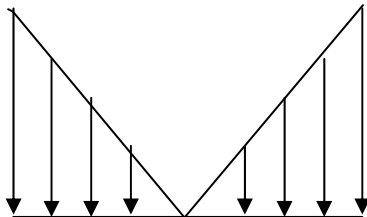
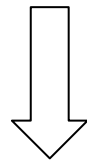
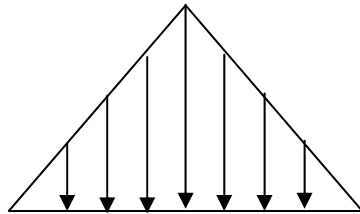
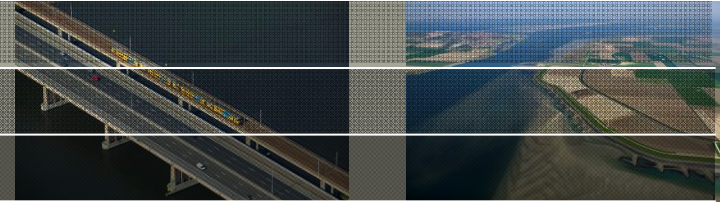

Herman-Jaap  
Lodder

◆ EBGEO/CUR

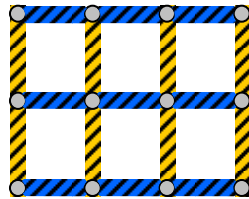
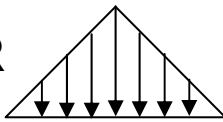

▼

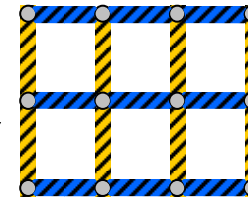
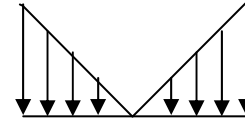

▲ gemeten

●

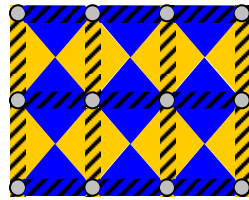
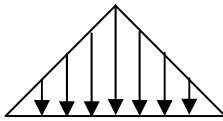

■

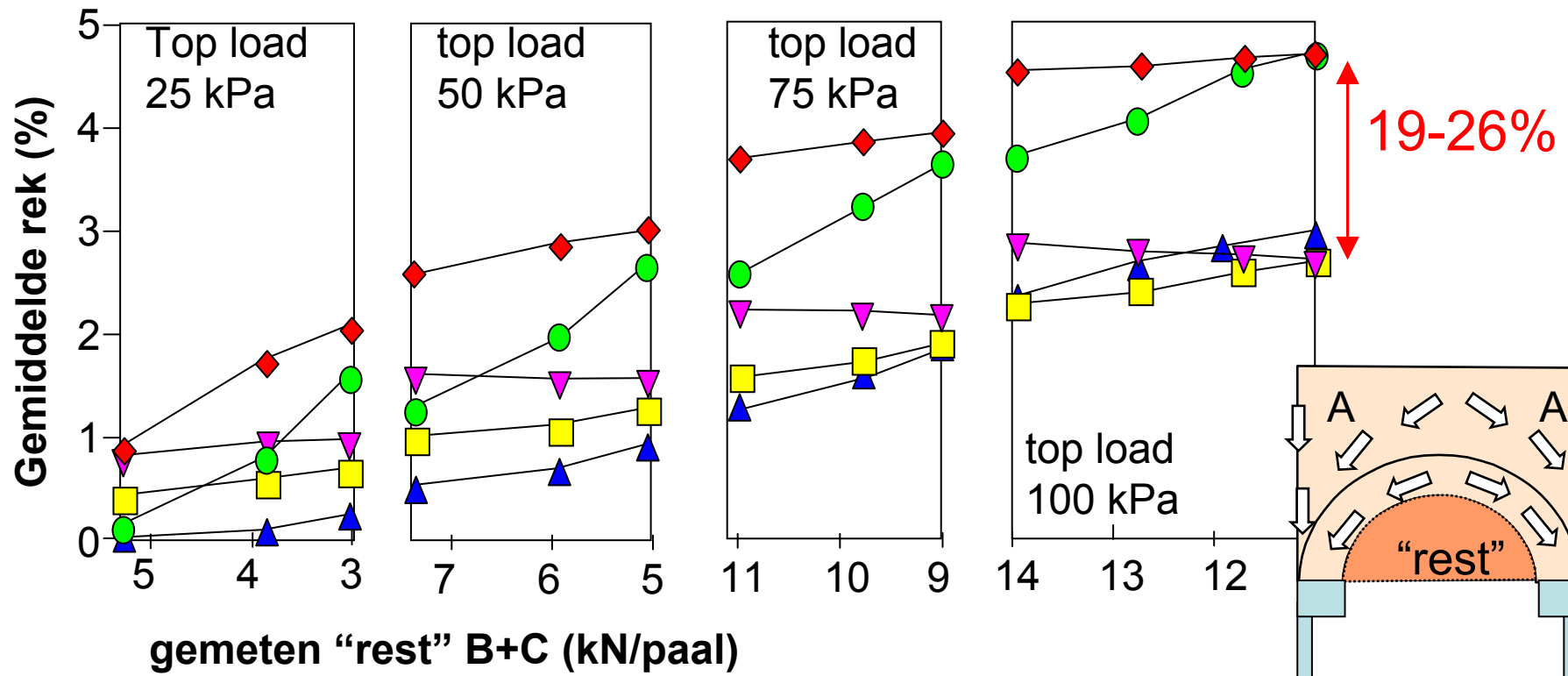
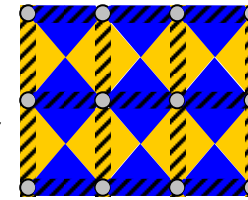
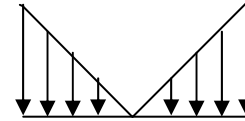

# Conclusies

- EBGEO/CUR berekent hogere rekken dan we meten.

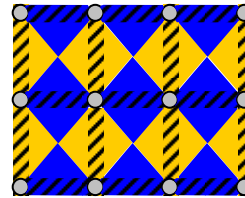
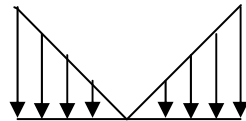

- Stap 2: inverse driehoek en aangepaste ondergrondmodel geven betere overeenstemming met metingen
- Deze aanpassingen geven (voor dit geval) een besparing in de benodigde GR sterkte van 19-26%.
- Aanpassingen stap 1: wordt aan gewerkt

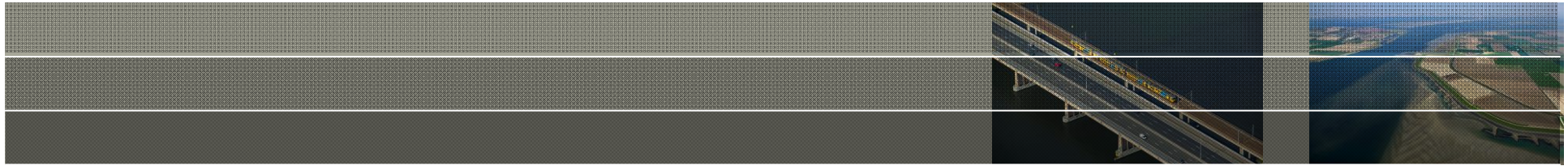

Met dank aan:

Huesker, Naue, TenCate, Tensar

TU-Afstudeerders Herman-Jaap Lodder en Theresa den Boogert

Deltares, Delft Cluster

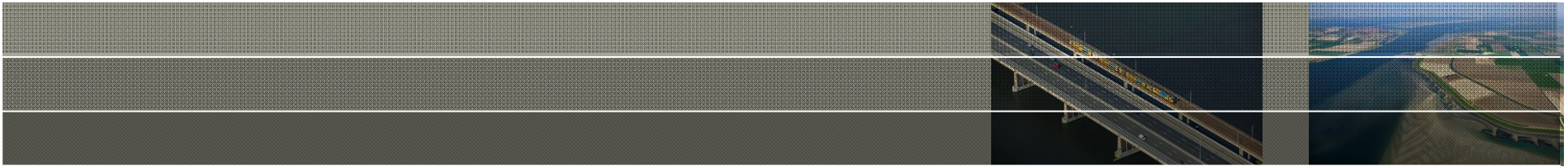

Bedankt voor de aandacht!

